

SECTION E-E

SCALE 1.5 : 1

UNLESS OTHERWISE SPECIFIED:
DIMENSIONS ARE IN INCHES

UNLESS OTHERWISE SPECIFIED, TOLERANCES:
LINEAR: DIMENSIONS UNDER 5/8 INCH ± 0.012
DIMENSIONS 5/8 INCH AND OVER ± 0.04
ANGULAR: ±0.5°

REMOVE ALL BURRS AND SHARP EDGES
0.02 RADIUS OR CHAMFER MAX

MATERIAL: BRASS, STEEL, RUBY AGATE

TITLE:
PRECISION OILER

 CLICKSPRINGPROJECTS.COM

A4

PROJECT MATERIALS LIST

Use nearest Imperial equivalent as appropriate.
Use desired material (Brass, wood, aluminum etc).

- 100mm x 1.0mm Blued Pivot Steel
- 100mm x 1.5mm Blued Pivot Steel
- 48.0mm x 13.0mm Round
- 42.0mm x 30.0mm Round
- 25.4mm x 70.0mm Round
- 4.78mm x 135mm Hex Rod

- Jewel Cups:

- BERGEON Product ID:
 - BERG-30180-AG-10MM
 - BERG-30180-AG-9MM

As of FEB 2019 available from www.ofrei.com

- Watchmakers Pith wood as required (can be sourced on Ebay)

UNLESS OTHERWISE SPECIFIED: DIMENSIONS ARE IN INCHES	TITLE: PRECISION OILER		CLICKSPRINGPROJECTS.COM	A4
UNLESS OTHERWISE SPECIFIED, TOLERANCES: LINEAR: DIMENSIONS UNDER 5/8 INCH ± 0.012 DIMENSIONS 5/8 INCH AND OVER ± 0.04 ANGULAR: ±0.5°				
REMOVE ALL BURRS AND SHARP EDGES 0.02 RADIUS OR CHAMFER MAX				
MATERIAL: BRASS, STEEL, RUBY AGATE				
COPYRIGHT © CLICKSPRING 2019	SCALE:		SHEET 2 OF 11	

ITEM NO.	PART NUMBER	QTY.
1	Base	1
2	Mid - Lower	1
3	Mid - Upper	1
4	Top	1
5	Jewel Cup	2
6	Pith Wood Insert	1

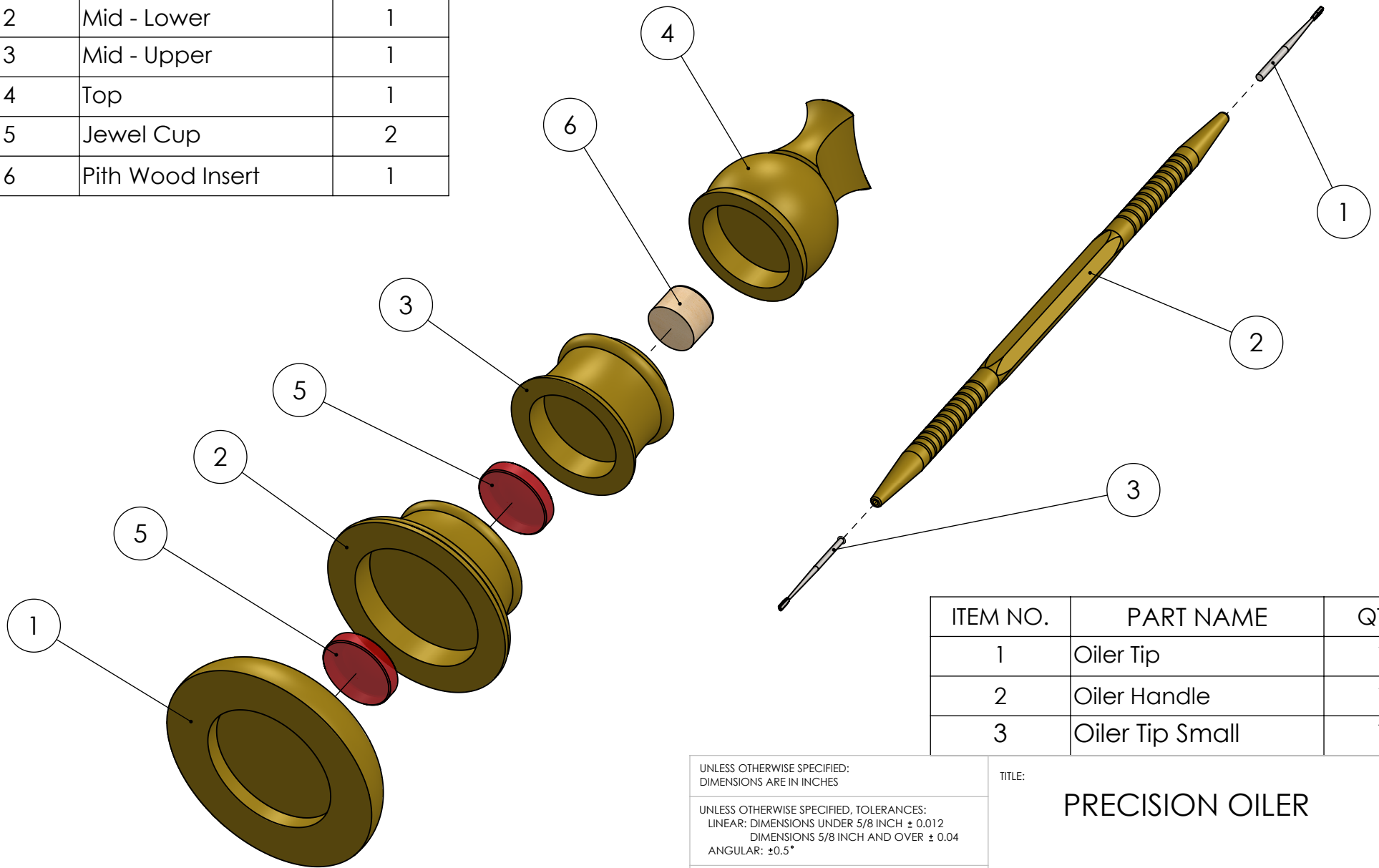

ITEM NO.	PART NAME	QTY.
1	Oiler Tip	1
2	Oiler Handle	1
3	Oiler Tip Small	1

UNLESS OTHERWISE SPECIFIED:
DIMENSIONS ARE IN INCHES

UNLESS OTHERWISE SPECIFIED, TOLERANCES:
LINEAR: DIMENSIONS UNDER 5/8 INCH ± 0.012
DIMENSIONS 5/8 INCH AND OVER ± 0.04
ANGULAR: $\pm 0.5^\circ$

REMOVE ALL BURRS AND SHARP EDGES
0.02 RADIUS OR CHAMFER MAX

MATERIAL: BRASS, STEEL, RUBY AGATE

TITLE:

PRECISION OILER



CLICKSPRINGPROJECTS.COM

A4

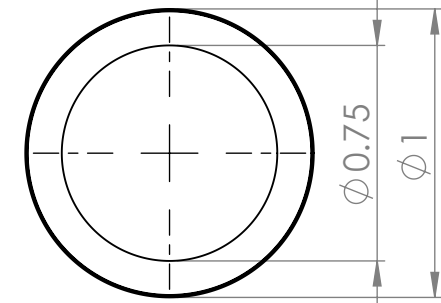
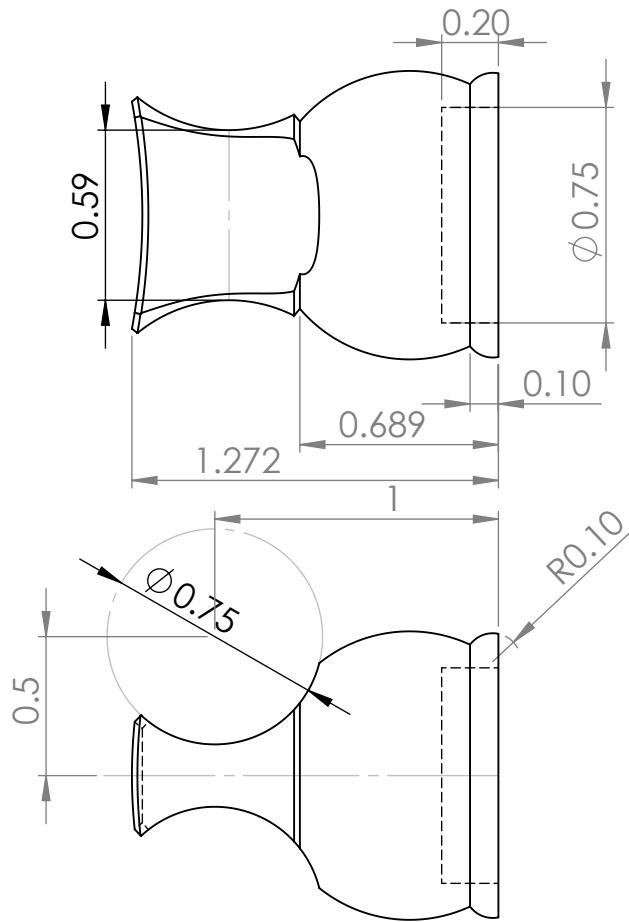
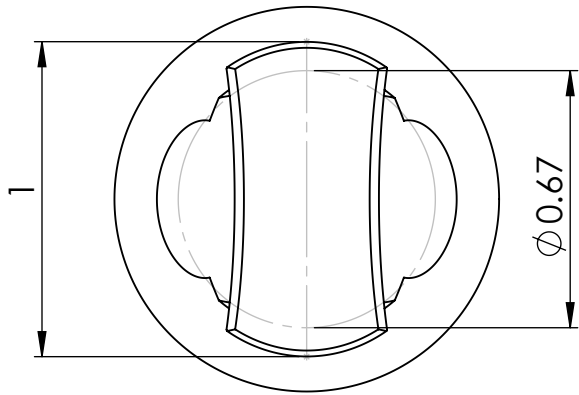

UNLESS OTHERWISE SPECIFIED:
DIMENSIONS ARE IN INCHES

UNLESS OTHERWISE SPECIFIED, TOLERANCES:
LINEAR: DIMENSIONS UNDER 5/8 INCH ± 0.012
DIMENSIONS 5/8 INCH AND OVER ± 0.04
ANGULAR: $\pm 0.5^\circ$

REMOVE ALL BURRS AND SHARP EDGES
0.02 RADIUS OR CHAMFER MAX

MATERIAL: BRASS

COPYRIGHT © CLICKSPRING 2019

TITLE:

TOP



CLICKSPRINGPROJECTS.COM

A4

SCALE: 1:1

SHEET 4 OF 11

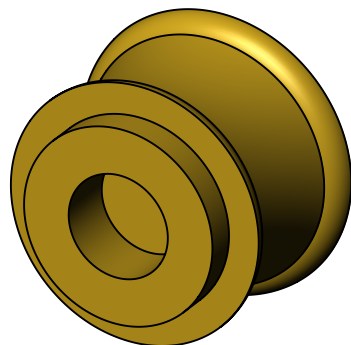
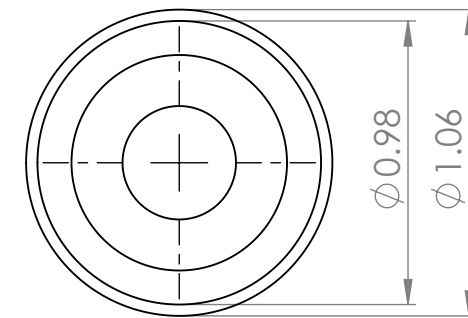
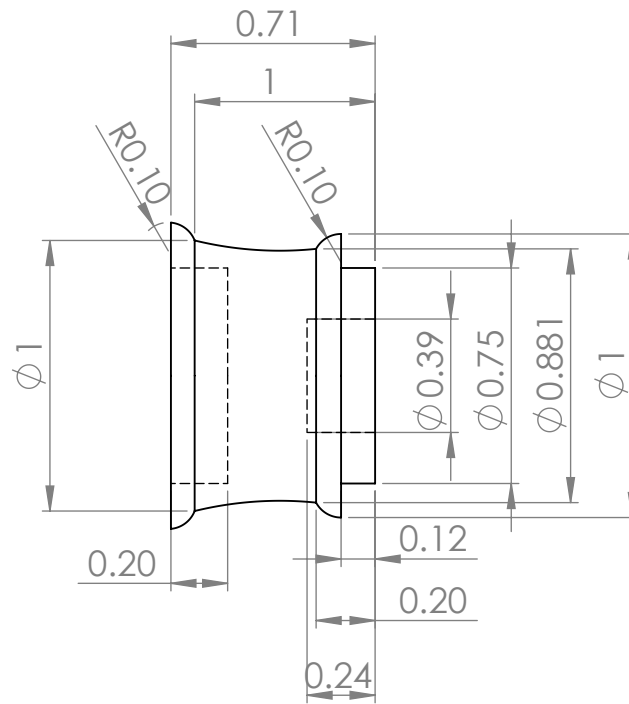
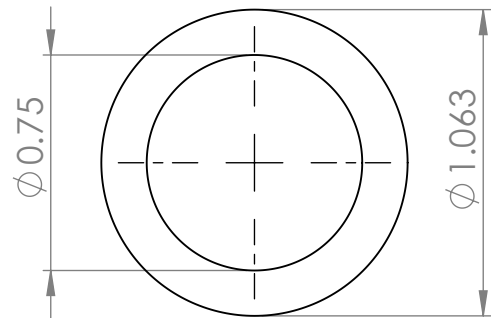

UNLESS OTHERWISE SPECIFIED:
DIMENSIONS ARE IN MILLIMETERS

UNLESS OTHERWISE SPECIFIED, TOLERANCES:
LINEAR: DIMENSIONS UNDER 15 MM ± 0.3
DIMENSIONS 15 MM AND OVER ± 1
ANGULAR: $\pm 0.5^\circ$

REMOVE ALL BURRS AND SHARP EDGES
0.50 RADIUS OR CHAMFER MAX

MATERIAL: BRASS

COPYRIGHT © CLICKSPRING 2019

TITLE:

MID UPPER



CLICKSPRINGPROJECTS.COM

A4

SCALE:

SHEET 5 OF 11

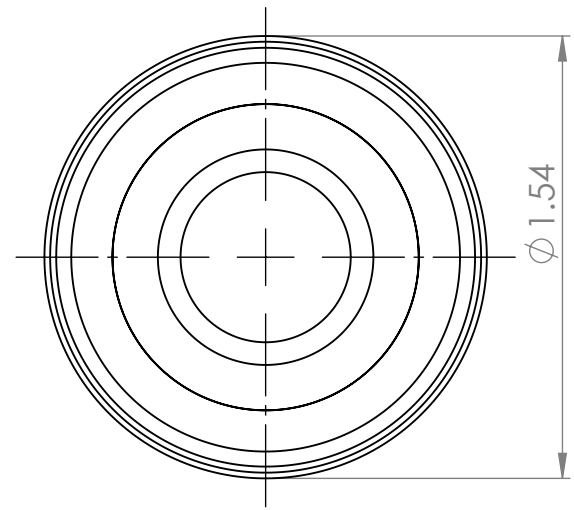
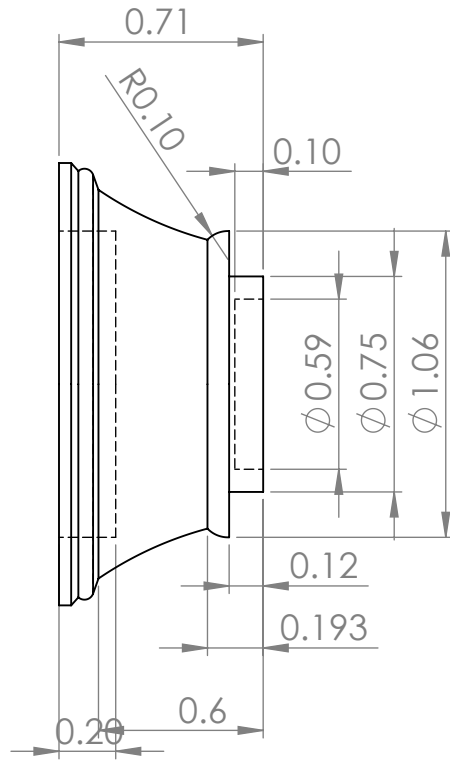
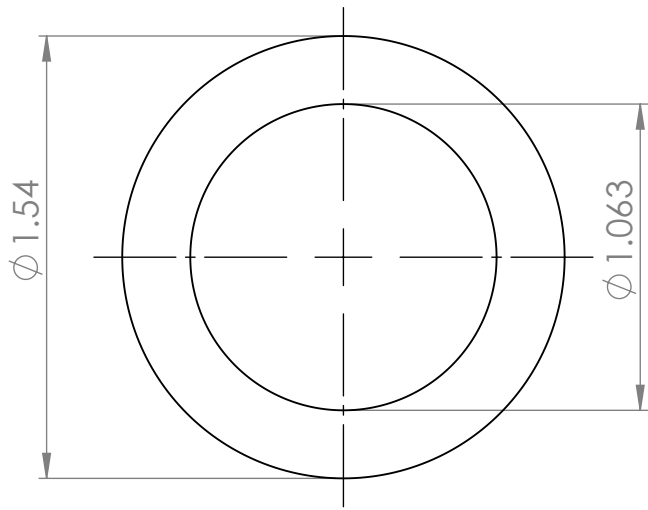

UNLESS OTHERWISE SPECIFIED:
DIMENSIONS ARE IN INCHES

UNLESS OTHERWISE SPECIFIED, TOLERANCES:
LINEAR: DIMENSIONS UNDER 5/8 INCH ± 0.012
DIMENSIONS 5/8 INCH AND OVER ± 0.04
ANGULAR: $\pm 0.5^\circ$

REMOVE ALL BURRS AND SHARP EDGES
0.02 RADIUS OR CHAMFER MAX

MATERIAL: BRASS

TITLE:

MID LOWER



CLICKSPRINGPROJECTS.COM

A4

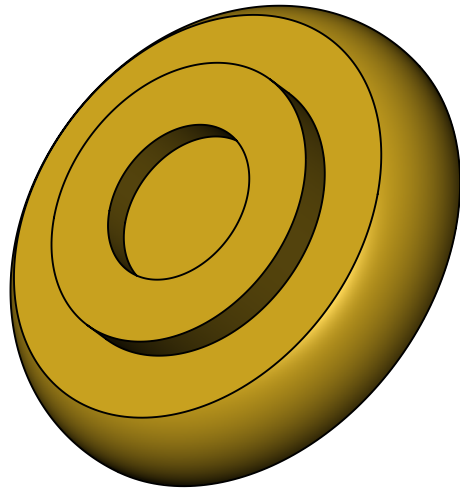
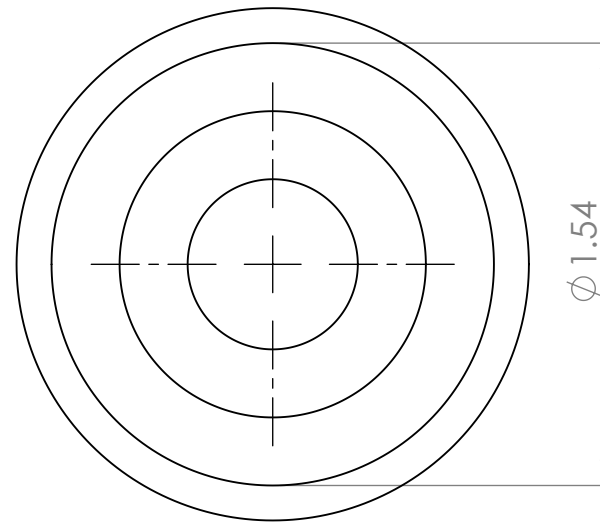
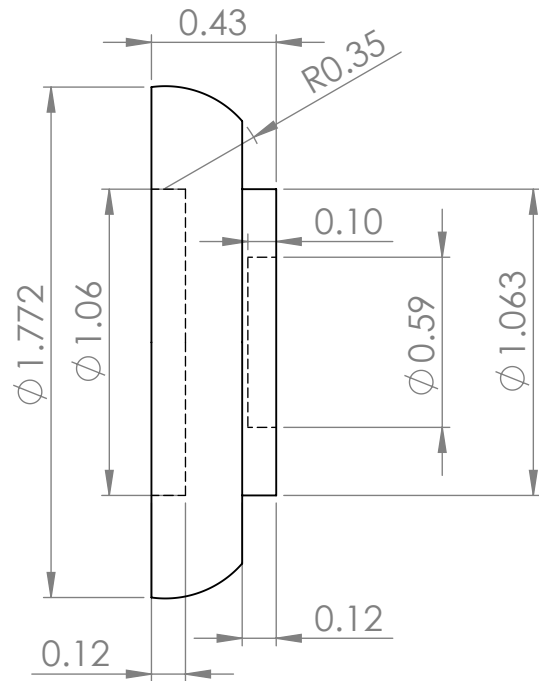

UNLESS OTHERWISE SPECIFIED:
DIMENSIONS ARE IN INCHES

UNLESS OTHERWISE SPECIFIED, TOLERANCES:
LINEAR: DIMENSIONS UNDER 5/8 INCH ± 0.012
DIMENSIONS 5/8 INCH AND OVER ± 0.04
ANGULAR: $\pm 0.5^\circ$

REMOVE ALL BURRS AND SHARP EDGES
0.02 RADIUS OR CHAMFER MAX

MATERIAL: BRASS

TITLE:

BASE



CLICKSPRINGPROJECTS.COM

A4

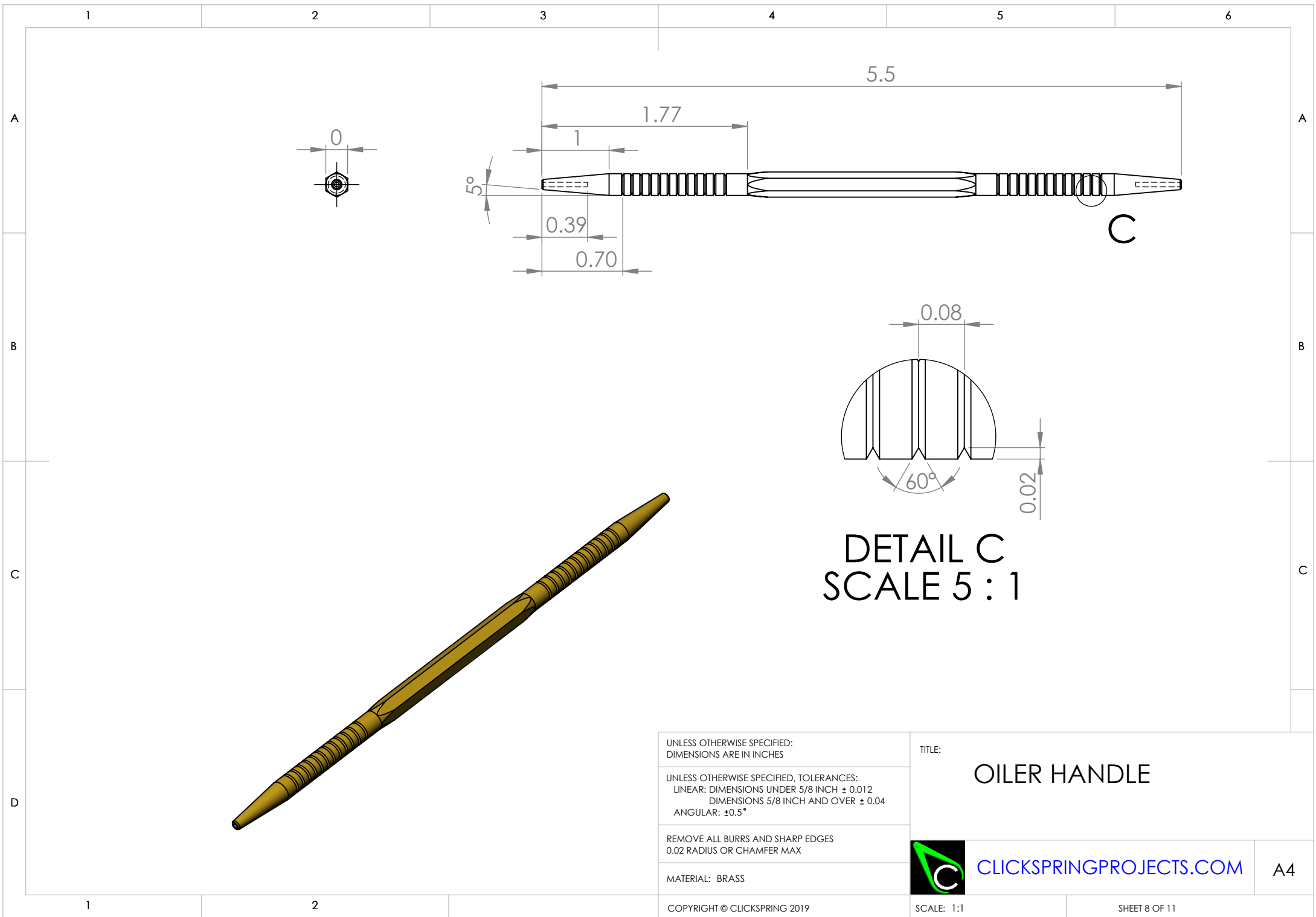

DETAIL C
SCALE 5 : 1

UNLESS OTHERWISE SPECIFIED:
DIMENSIONS ARE IN INCHES

UNLESS OTHERWISE SPECIFIED, TOLERANCES:
LINEAR: DIMENSIONS UNDER 5/8 INCH ± 0.012
DIMENSIONS 5/8 INCH AND OVER ± 0.04
ANGULAR: ±0.5°

REMOVE ALL BURRS AND SHARP EDGES
0.02 RADIUS OR CHAMFER MAX

MATERIAL: BRASS

TITLE: OILER HANDLE

 CLICKSPRINGPROJECTS.COM A4

1 2 3 4 5 6

A

A

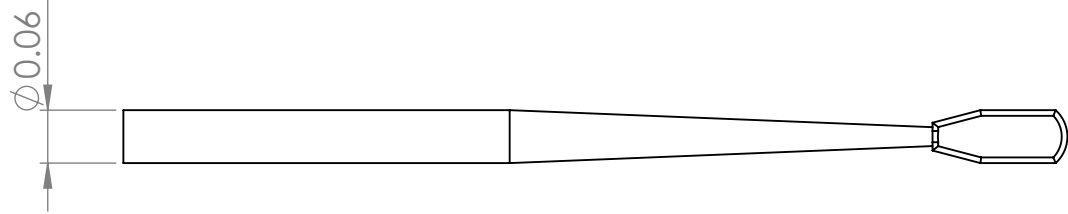

NOTES, UNLESS OTHERWISE SPECIFIED:

- 1. DIMENSIONS NOMINAL, SHAPE AS REQUIRED FROM PIVOT STEEL, REFER VIDEO.

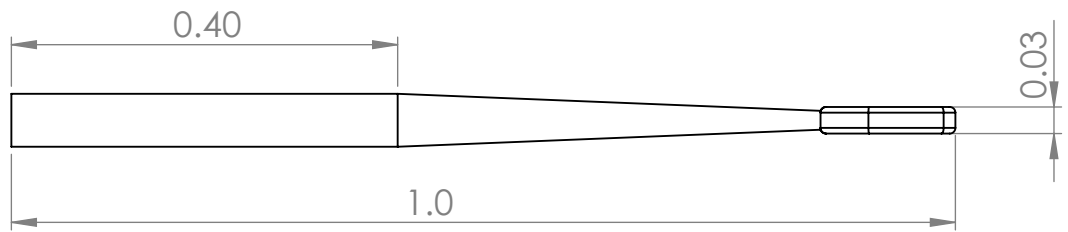

B

B

C

C

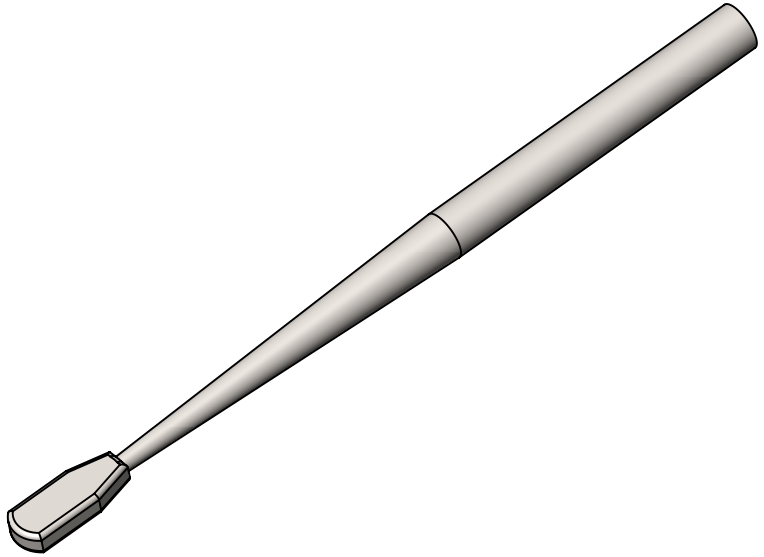

D

D

UNLESS OTHERWISE SPECIFIED:
DIMENSIONS ARE IN INCHES

UNLESS OTHERWISE SPECIFIED, TOLERANCES:
LINEAR: DIMENSIONS UNDER 5/8 INCH ± 0.012
DIMENSIONS 5/8 INCH AND OVER ± 0.04
ANGULAR: $\pm 0.5^\circ$

REMOVE ALL BURRS AND SHARP EDGES
0.02 RADIUS OR CHAMFER MAX

MATERIAL: PLAIN CARBON STEEL

TITLE: OILER NIB

 CLICKSPRINGPROJECTS.COM A4

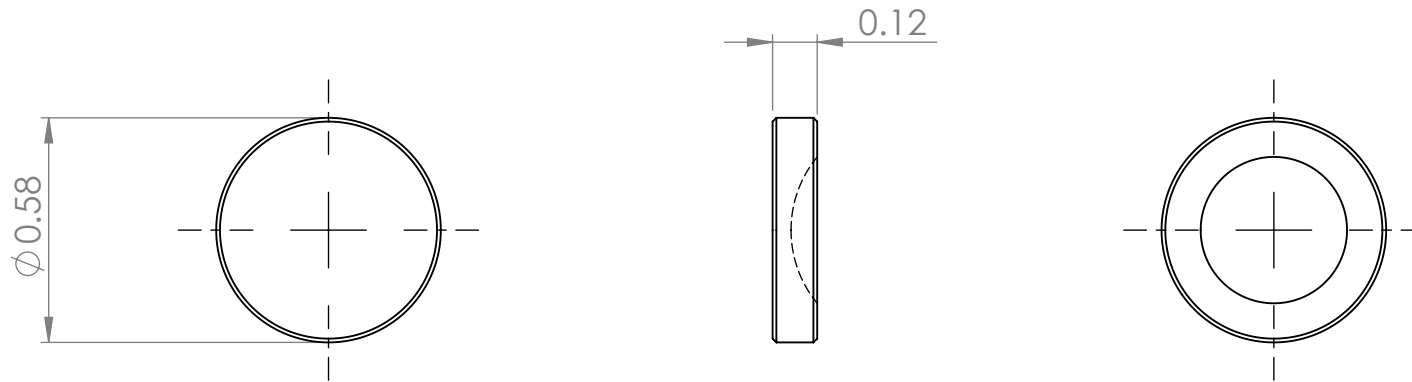

NOTES, UNLESS OTHERWISE SPECIFIED:

1. BERGEON Product ID:
 - BERG-30180-AG-10MM
 - BERG-30180-AG-9MM

As of FEB 2019 available from www.ofrei.com

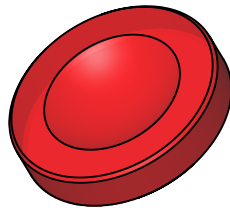

UNLESS OTHERWISE SPECIFIED:
DIMENSIONS ARE IN INCHES

UNLESS OTHERWISE SPECIFIED, TOLERANCES:
LINEAR: DIMENSIONS UNDER 5/8 INCH ± 0.012
DIMENSIONS 5/8 INCH AND OVER ± 0.04
ANGULAR: $\pm 0.5^\circ$

REMOVE ALL BURRS AND SHARP EDGES
0.02 RADIUS OR CHAMFER MAX

MATERIAL: AGATE RUBY

TITLE:

JEWEL CUP



CLICKSPRINGPROJECTS.COM

A4

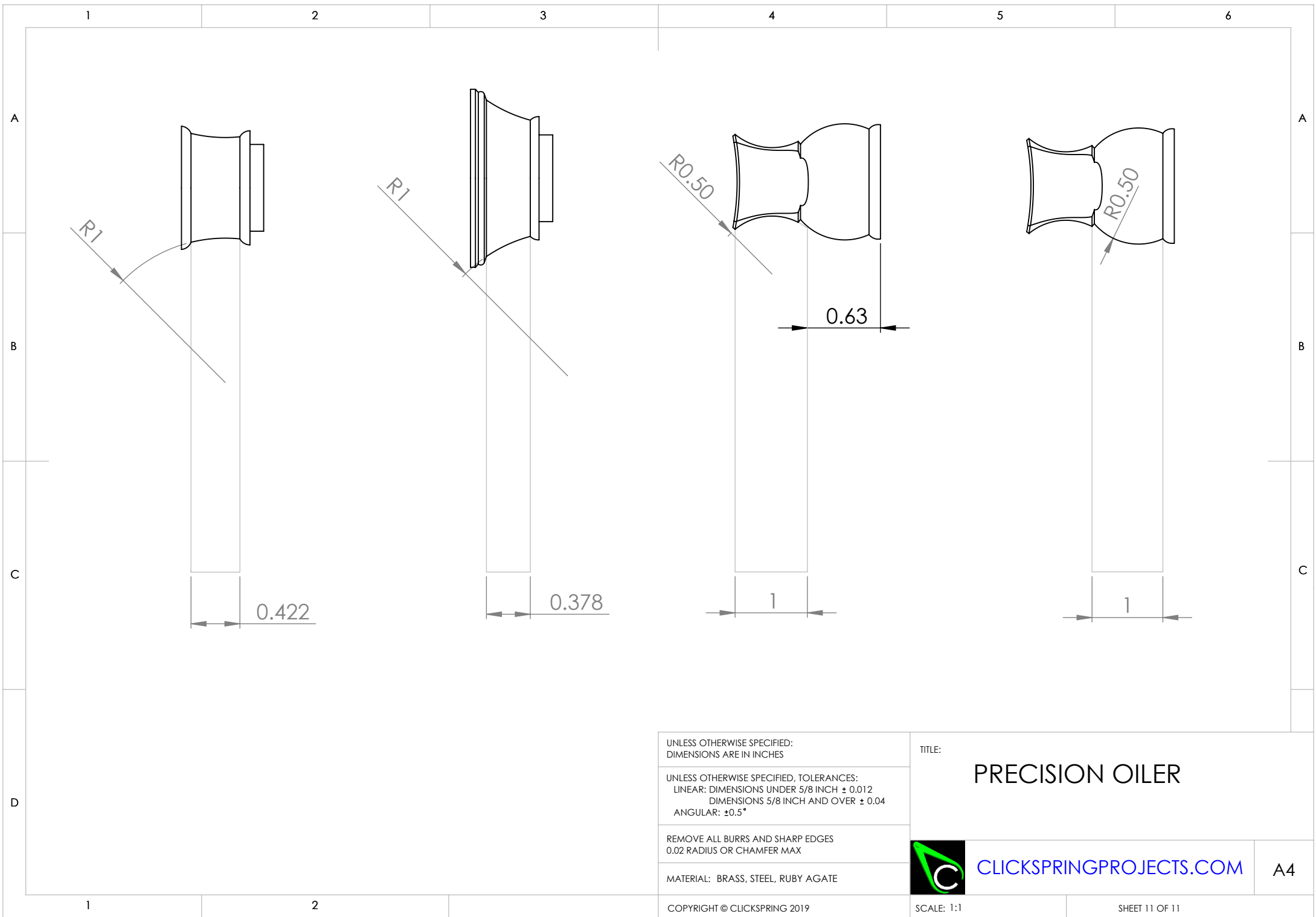

UNLESS OTHERWISE SPECIFIED:
DIMENSIONS ARE IN INCHES

UNLESS OTHERWISE SPECIFIED, TOLERANCES:
LINEAR: DIMENSIONS UNDER 5/8 INCH ± 0.012
DIMENSIONS 5/8 INCH AND OVER ± 0.04
ANGULAR: $\pm 0.5^\circ$

REMOVE ALL BURRS AND SHARP EDGES
0.02 RADIUS OR CHAMFER MAX

MATERIAL: BRASS, STEEL, RUBY AGATE

COPYRIGHT © CLICKSPRING 2019

TITLE:
PRECISION OILER

 CLICKSPRINGPROJECTS.COM

A4

SCALE: 1:1

SHEET 11 OF 11