

1 2 3 4 5 6

A

A

B

B

C

C

D

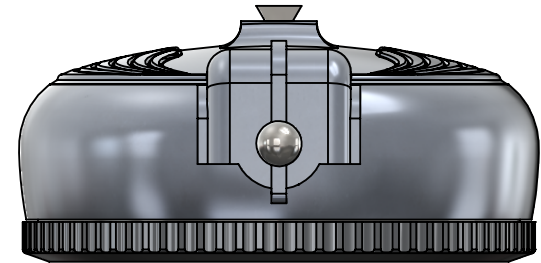
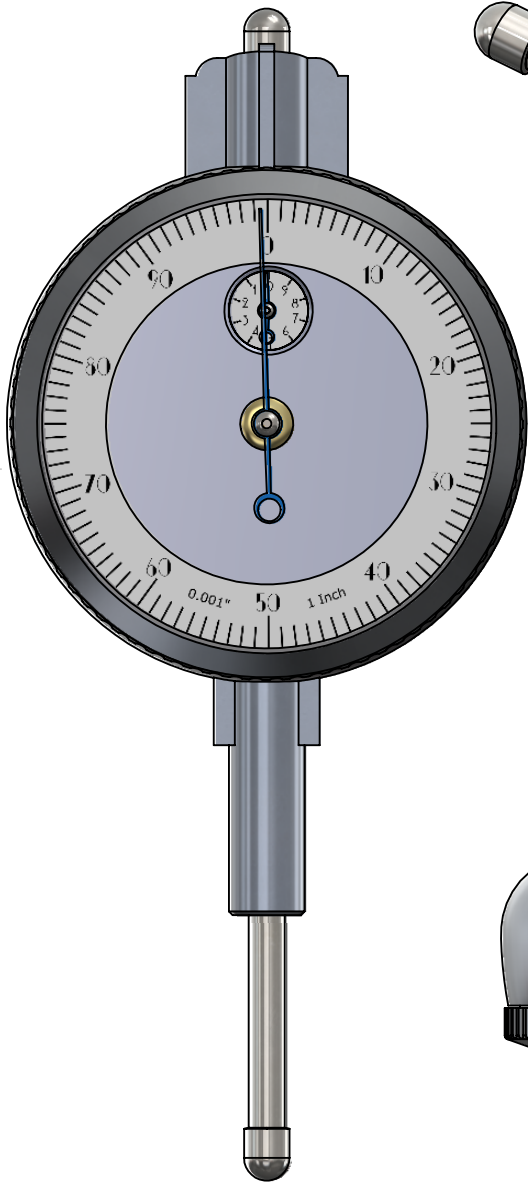
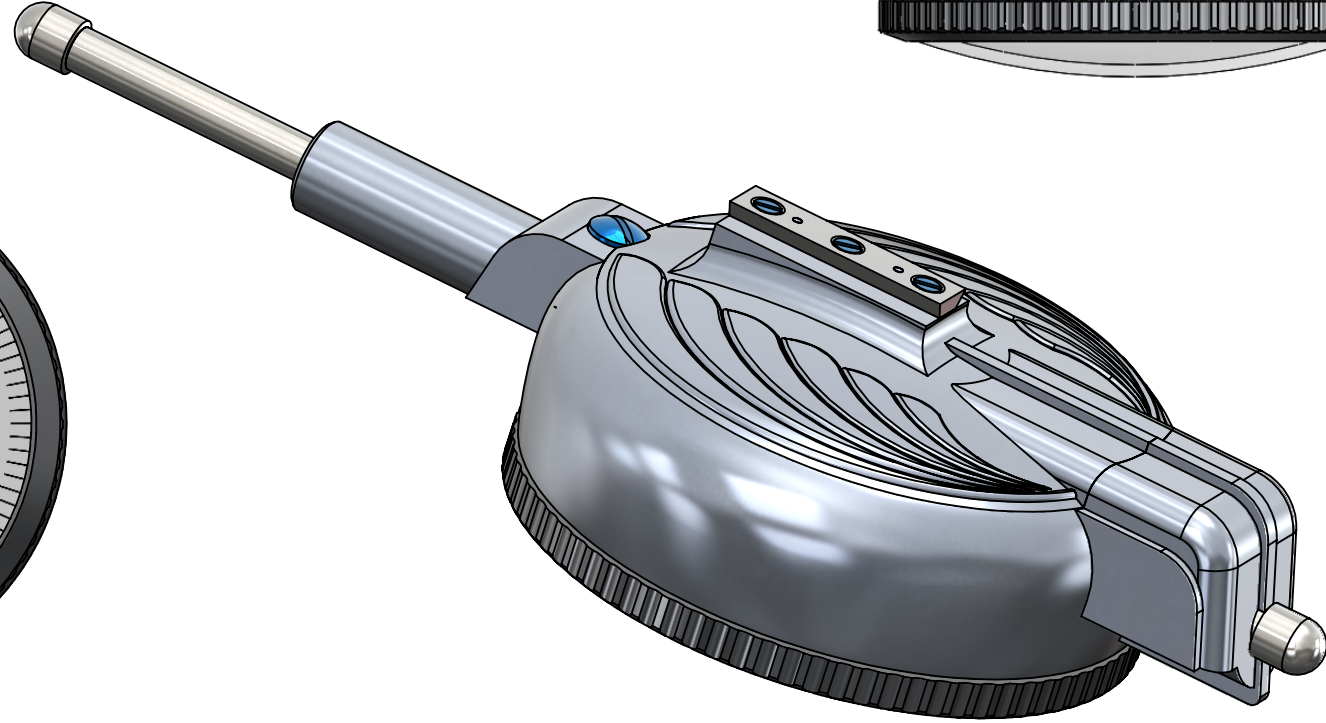
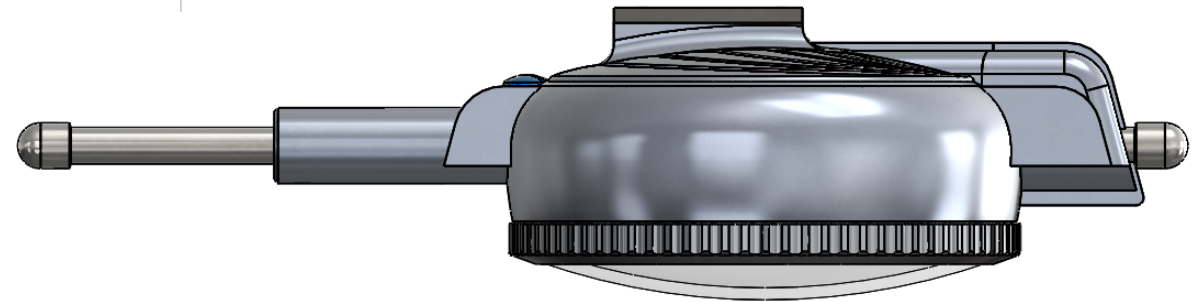

TITLE:

CLICKSPRING DIAL INDICATOR



CLICKSPRINGPROJECTS.COM

A4

ITEM NO.	PART NUMBER	QTY.
1	Main Plate	1
2	Chassis	1
3	Indicator Shaft Assembly	1
4	Bezel Assembly	1
5	Case Back Fastener	1
6	Center Pinion Assembly	1
7	Inner Dial Assembly	1
8	Bridge Plate	1
9	Hairspring Fastener	1
10	Bridge Plate Fastener	3
11	Main Plate Fasteners	2
12	Backlash Wheel Assembly	1
13	Drive Wheel Assembly	1
14	Case Back Assembly	1

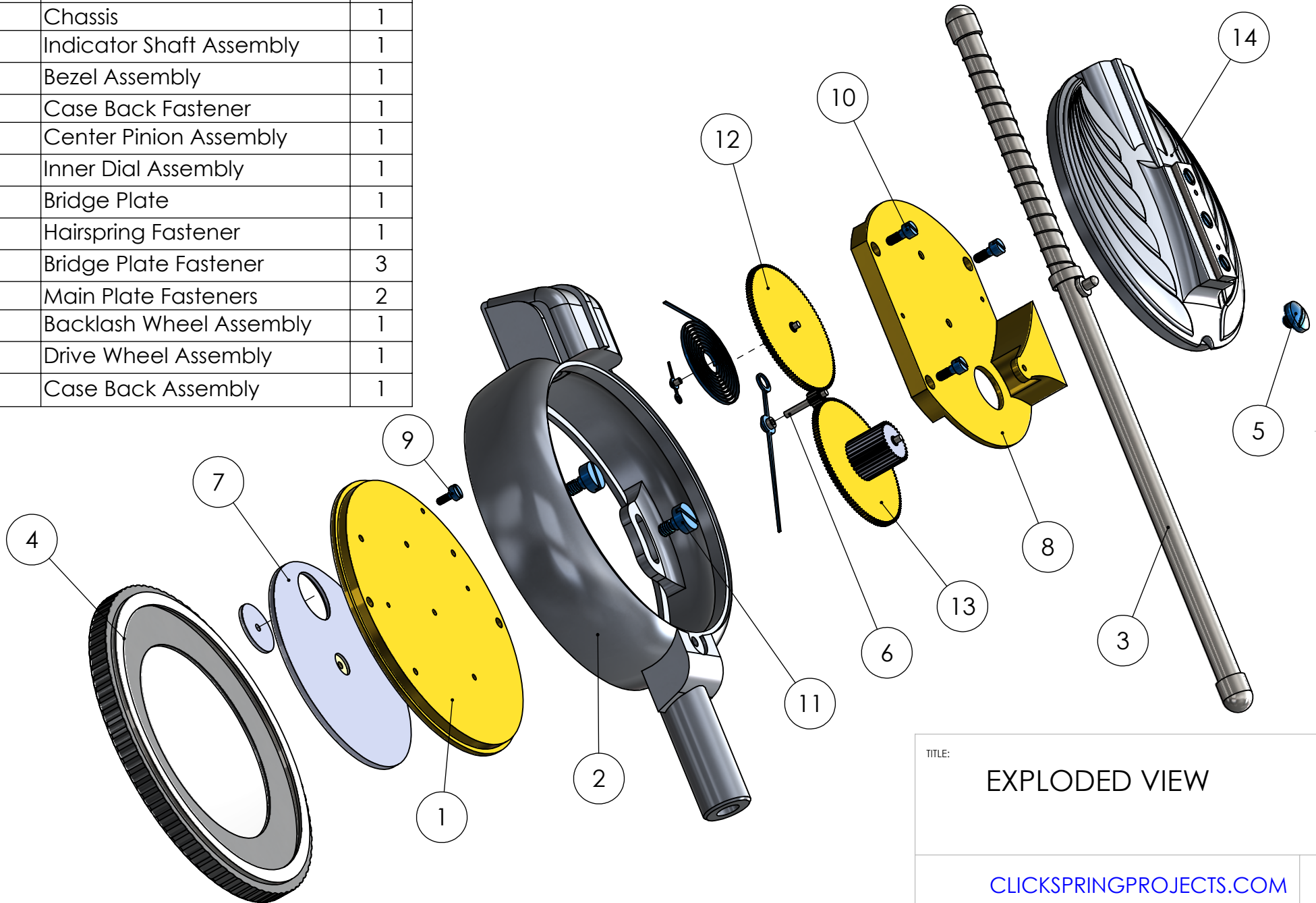

TITLE:

EXPLODED VIEW

CLICKSPRINGPROJECTS.COM

A4

MAIN PROJECT MATERIALS LIST

Use nearest Imperial equivalent as appropriate.
All Brass sheet, engravers brass, hard temper.
One of each as follows, unless otherwise specified:

- 6.0mm Brass Sheet - 70mm x 70mm (Bezel Upper)
- 5.0mm Brass Sheet - 70mm x 70mm (Bezel Lower)
- 3.0mm Brass Sheet - 65mm x 65 mm (Main Plate)
- 1.5mm Brass Sheet - 65mm x 65mm (Crystal Height Adj. Insert)
- 1.0mm Brass Sheet - 30mm x 60mm (Drive & Backlash Wheels)
- 0.7mm Brass Sheet - 65mm x 65 mm (Outer Dial)

- 1.2mm Sheet of desired material - 50mm x 50mm (Dial Inner)
- 0.7mm Sheet of desired material - 15mm x 15mm (Inset Dial)

- 10.0mm Brass Rod - 40mm (Collet Pot Chuck)
- 8.0mm Brass Rod - 100mm (Dial Inner Insert, Spring Winding Tool)
- 6.0mm Brass Rod - 40mm (Collet Pot Chuck, Various Stub Arbor)
- 5.0mm Brass Rod - 100mm (Return Spring Former)
- 4.0mm Brass Rod - 70mm (Hairspring Collet)
-
- Blued Pivot Steel - 5mm x 125mm (Arbors)

- 9mm Medium Carbon Steel (EN8) - 80mm (30T, 12t Pinions)
- 7mm Medium Carbon Steel (EN8) - 80mm (Probe Tips, Spring Retaining Cup, Fasteners)
- 5mm Medium Carbon Steel (EN8) - 80mm (Hand Bosses, Guide Pin, Fasteners)

- 10mm O1 Drill Rod - 30mm (Button Cutter For Gear Forming)
- 4.76mm (3/16") Drill Rod - 150mm (Probe)

- 0.6mm Gauge Plate - 15mm x 50mm (Hands)
- 2.0mm Gauge Plate - 10mm x 30mm (Dovetail)
- 5.0mm Gauge Plate - 30mm x 160mm (Gear Cutters)

- 10mm Mild Steel Bar - 10mm x 300mm (Button Cutter Holders)

- Size 12 (0.31mm) Carbon Steel Guitar String (Return Spring)

IF FABRICATING BRIDGE PLATE

- 4.0mm Brass Sheet - 50mm x 60mm
- Brass Bar - 10mm x 20mm x 25mm

CASTING REQUIREMENTS

If choosing to cast the Chassis & Case Back, refer STL files for casting molds.

- Brass, Bronze or Nickel Silver (2.5Kg)
- Aluminium (0.8Kg)

REQUIRED GEAR CUTTERS

Refer to "Tools, Glorious Tools!" Ep 10 (parts 1 to 5) for instructions on how to make small module gear cutters.

- **120 T Wheels: DP 112 / M 0.2268**
- **12 T Center Pinion: DP 112 / M 0.2268**
- **30 T Drive Pinion: DP 94.25 / M 0.2695**
- **Rack: DP 94.25 / M 0.2695**

OTHER

- Assorted Steel Clock Pins (refer any clock materials supplier)
- 60mm Watchglass - (Front crystal) (refer classroom science materials suppliers eg <https://www.madaboutscience.com.au>)
- Soft Solder/Flux or Loctite 603 as preferred
- 500mL Ferric Chloride (Dial etching)
- Shellac Dial Wax (Dial filling)
- Silvering Powder/Finishing Powder



BRIDGE PLATE FIXTURE

- 25mm Aluminium Plate - 70mm x 70mm
- 10mm Aluminium Plate - 50mm x 100mm
- 12mm EN8 Medium Carbon Steel - 30mm (Locating Pin)
- 6.0mm Dowel Pin x 4
- M5 SHCS 25mm x 2

INDICATOR SHAFT CUTTING FIXTURE

- 16mm Aluminium Plate - 55mm x 110mm
- 3.18mm (1/8") Brass Rod
- M6 Grub Screw x 2

CASE BACK FIXTURE

- M8 Grub Screw x 4
- 76.0MM Aluminium Rod Stock - 40MM
- 12.0MM Aluminium Plate 65mm x 65mm

SUGGESTED ALUMINIUM CA GLUE ARBOR STOCK

- 25.0MM x 100MM
- 33.0MM x 30MM
- 50.0MM x 120MM
- 60.0MM x 40MM
- 80.0mm X 140.0MM

IF PURCHASING THE HAIRSPRING

Some sizes within the commonly available "assorted box sets of 72 springs" will do the job. They can be sourced from most clock suppliers, as well as Amazon or Ebay eg:

<https://www.cousinsuk.com>
<https://www.hswalsh.com/>

IF JEWELLING THE MOVEMENT

- R127.0/RB22122 Olive Hole Ring Jewel x 6

Can be purchased from:

<https://www.swissjewel.com/>
<https://birdprecision.com>

Be sure to confirm that the stock is red ruby or clear sapphire, as per your preference, before purchase.

IF USING O-RINGS ON INDICATOR SHAFT

- 0.5MM X 4.3MM Buna-N 70 Duro Metric O-Ring x 2
- Can be purchased from:

<https://www.theoringstore.com/>

- P/N N0.50X004.3



ITEM NO.	PART NUMBER	QTY.
1	120 T Drive Wheel	1
2	30 T Drive Pinion	1
3	Drive Wheel Arbor	1

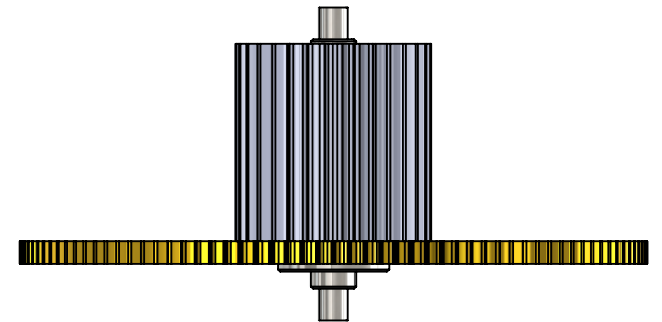
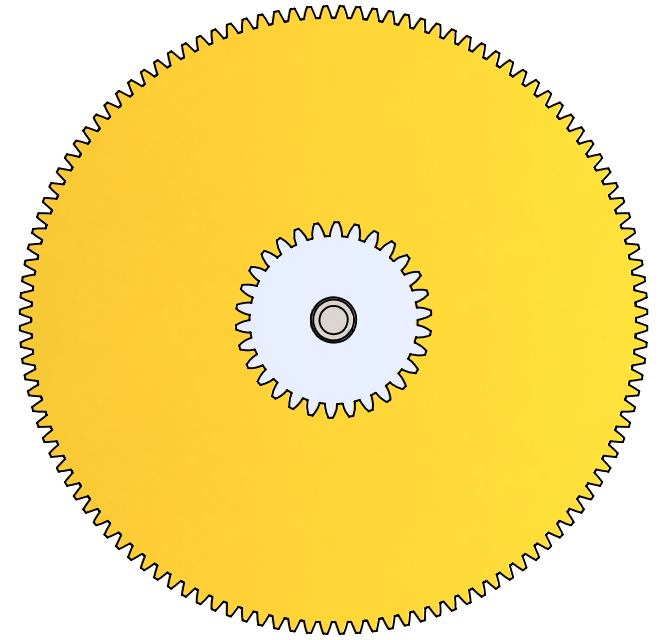
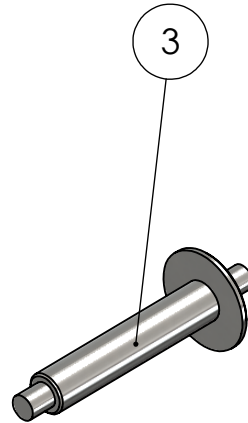
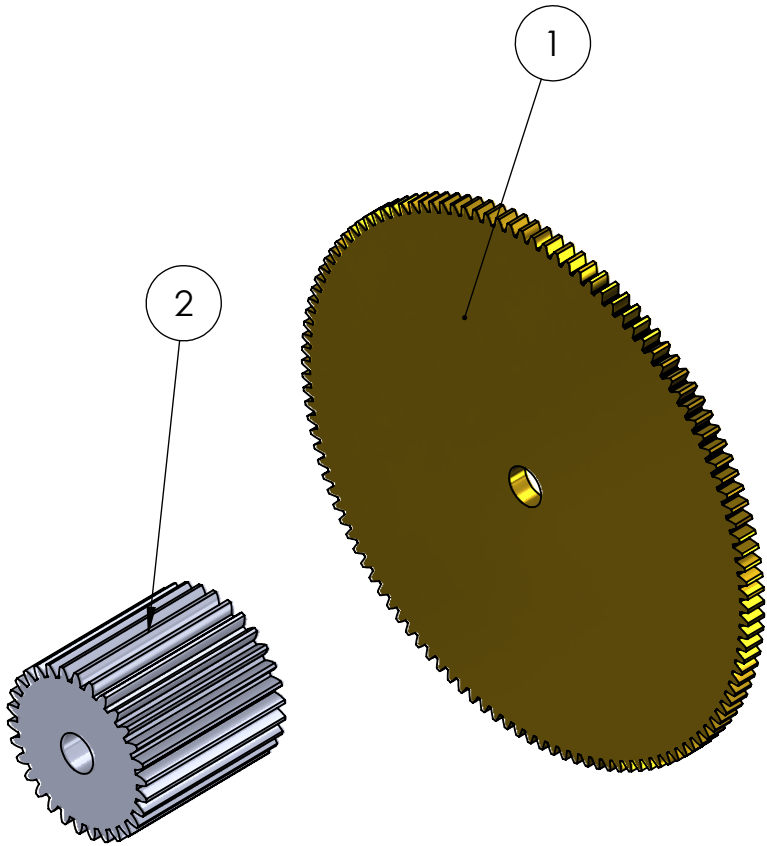

UNLESS OTHERWISE SPECIFIED:
DIMENSIONS ARE IN MILLIMETERS

UNLESS OTHERWISE SPECIFIED, TOLERANCES:
LINEAR:
DIMENSIONS ≤ 2 MM ± 0.01
DIMENSIONS > 2 MM & ≤ 50 MM ± 0.05
DIMENSIONS > 50 ± 0.15
ANGULAR:
 $\pm 0.25^\circ$

MATERIAL: BRASS, STEEL

TITLE:

DRIVE WHEEL ASSEMBLY



CLICKSPRINGPROJECTS.COM

A4

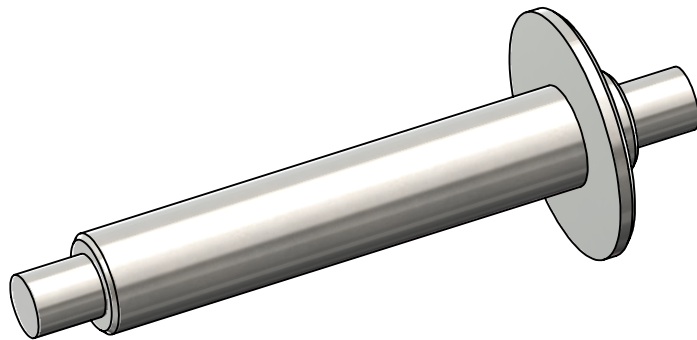
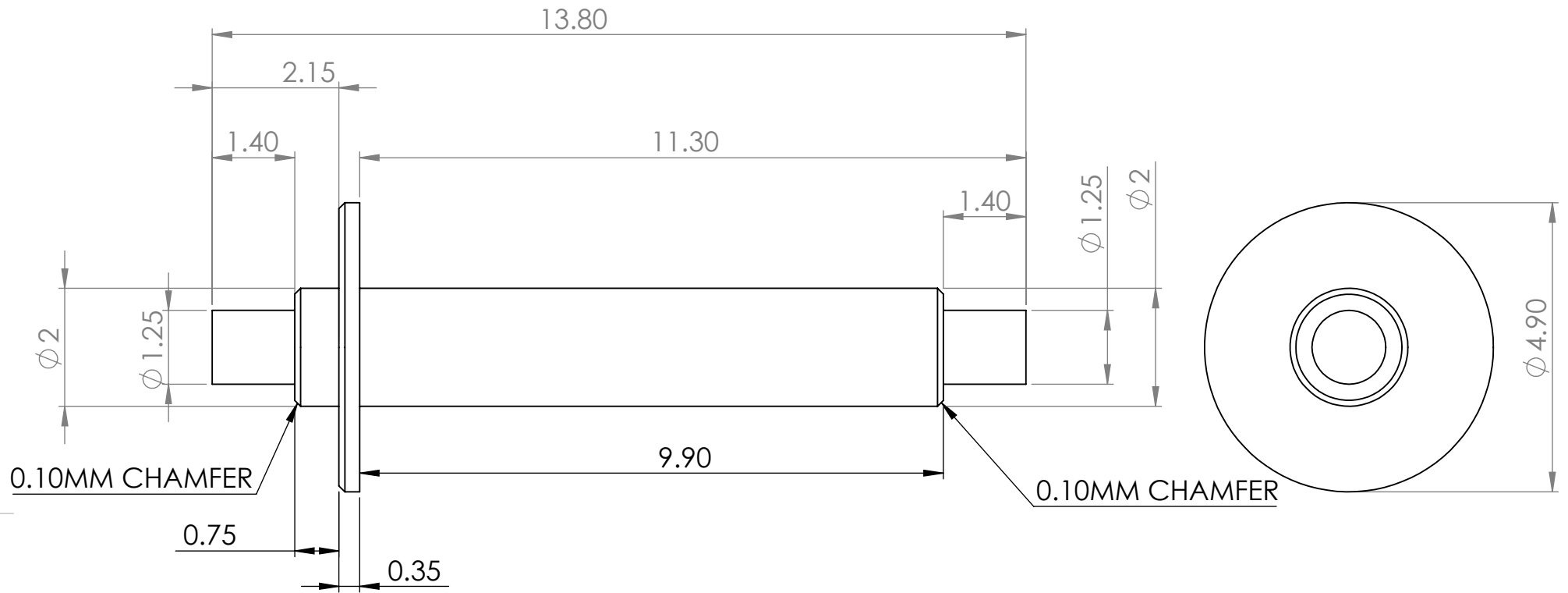

UNLESS OTHERWISE SPECIFIED:
DIMENSIONS ARE IN MILLIMETERS

UNLESS OTHERWISE SPECIFIED, TOLERANCES:
LINEAR:
DIMENSIONS ≤ 2 MM ± 0.01
DIMENSIONS > 2 MM & ≤ 50 MM ± 0.05
DIMENSIONS > 50 ± 0.15
ANGULAR:
 $\pm 0.25^\circ$

MATERIAL: BLUED PIVOT STEEL

TITLE:

DRIVE WHEEL ARBOR



CLICKSPRINGPROJECTS.COM

A4

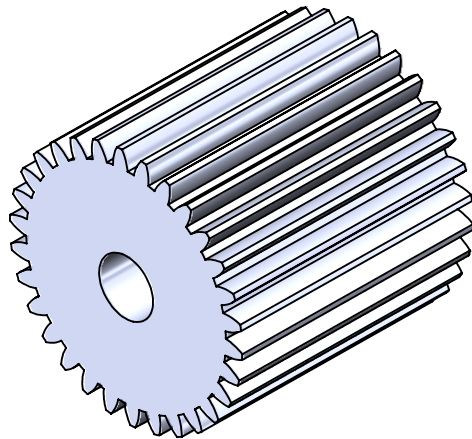
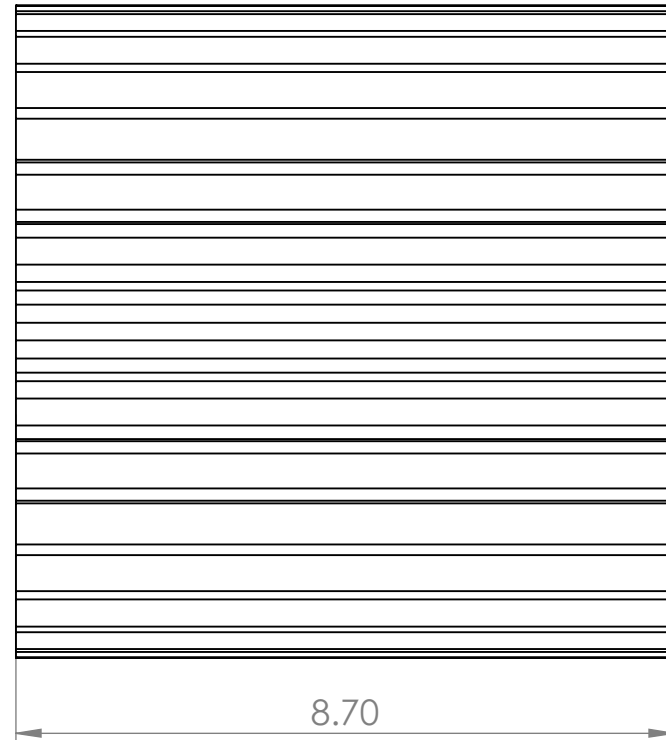
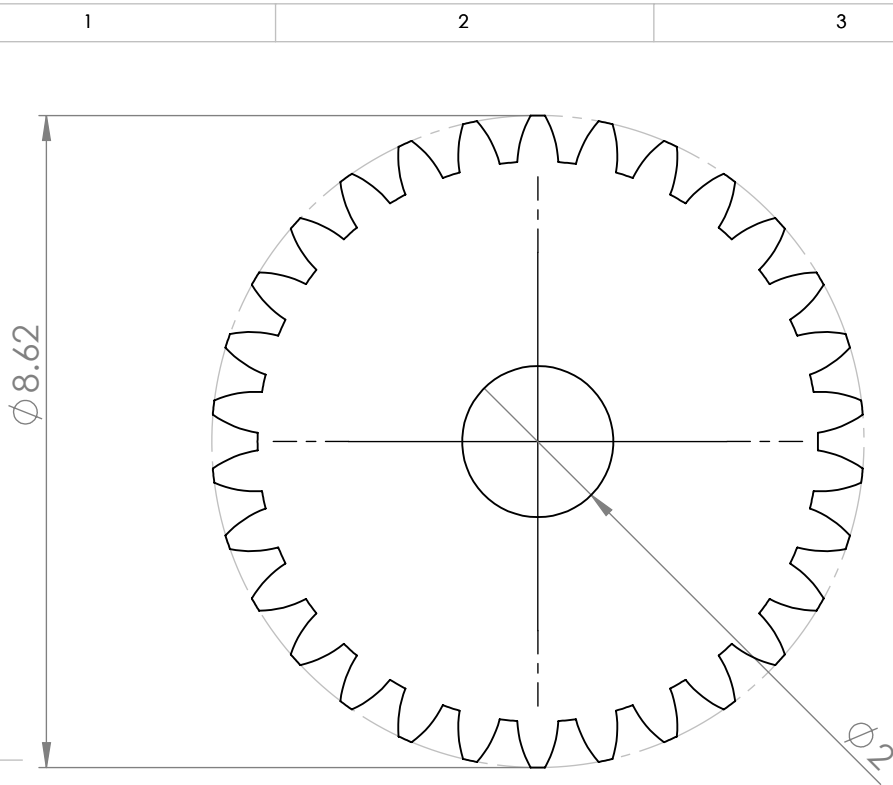

NOTES UNLESS OTHERWISE SPECIFIED:

- TEETH NUMBER = 30
- DIAMETRAL PITCH 94.25 / MODULE 0.2695

UNLESS OTHERWISE SPECIFIED:
DIMENSIONS ARE IN MILLIMETERS

UNLESS OTHERWISE SPECIFIED, TOLERANCES:
LINEAR:
DIMENSIONS ≤ 2 MM ± 0.01
DIMENSIONS > 2 MM & ≤ 50 MM ± 0.05
DIMENSIONS > 50 ± 0.15
ANGULAR:
 $\pm 0.25^\circ$

MATERIAL: MEDIUM CARBON STEEL (EN8)

TITLE:

30T DRIVE PINION



CLICKSPRINGPROJECTS.COM

A4

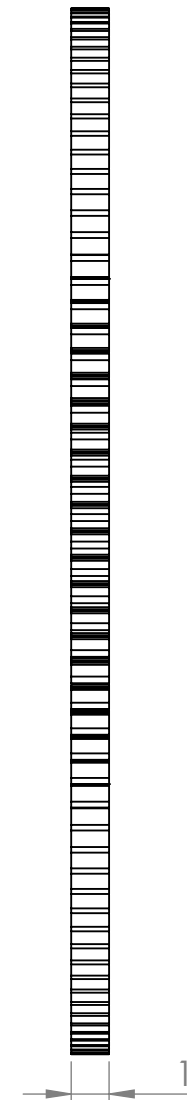
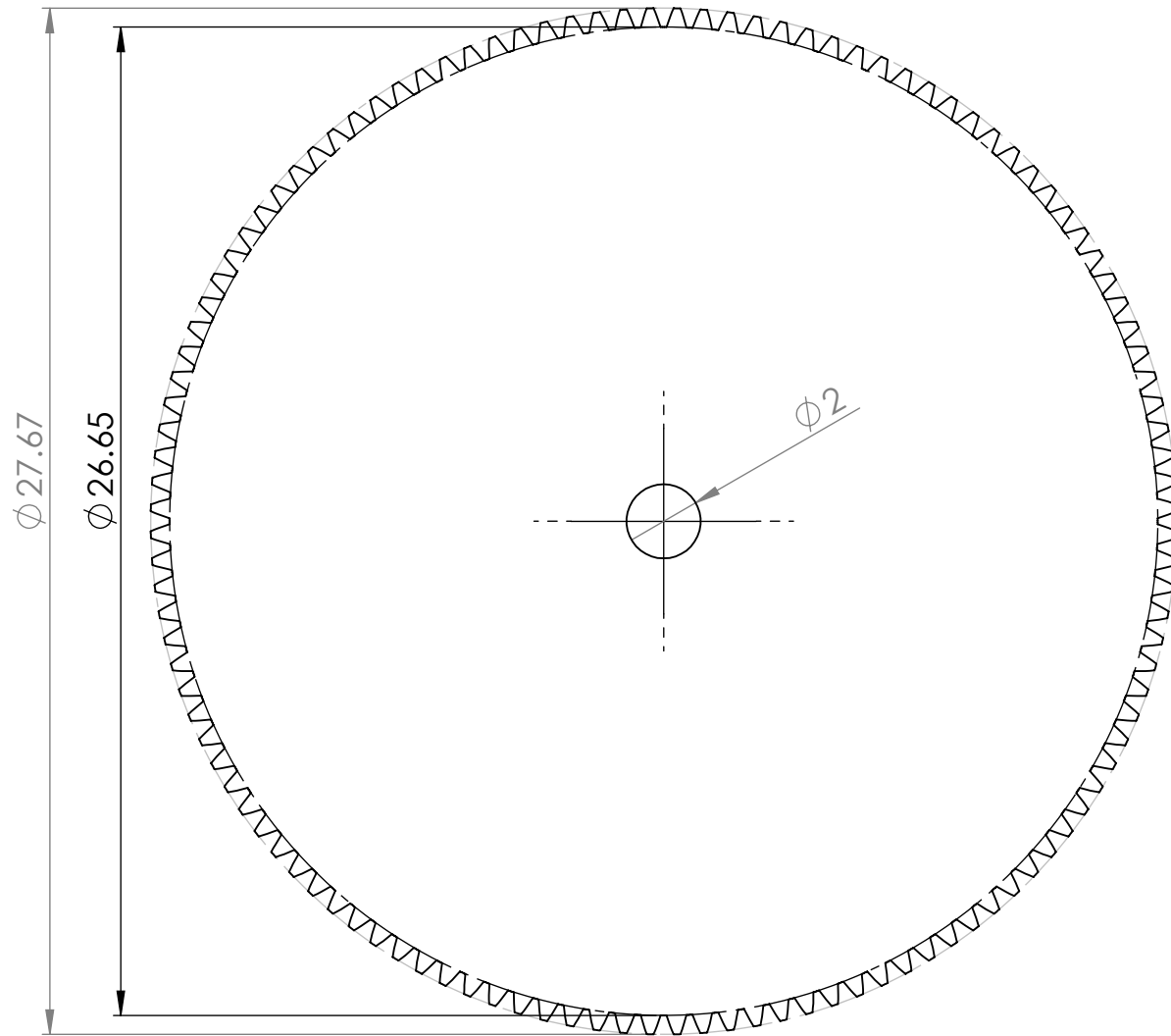

NOTES UNLESS OTHERWISE SPECIFIED:

- TEETH NUMBER = 120
- DIAMETRAL PITCH 112 / MODULE 0.2268

UNLESS OTHERWISE SPECIFIED:
DIMENSIONS ARE IN MILLIMETERS

UNLESS OTHERWISE SPECIFIED, TOLERANCES:
LINEAR:
DIMENSIONS ≤ 2 MM ± 0.01
DIMENSIONS > 2 MM & ≤ 50 MM ± 0.05
DIMENSIONS > 50 ± 0.15
ANGULAR:
 $\pm 0.25^\circ$

MATERIAL: BRASS

TITLE:

120T DRIVE WHEEL



CLICKSPRINGPROJECTS.COM

A4

ITEM NO.	PART NUMBER	QTY.
1	120 T Backlash Wheel	1
2	Backlash Wheel Arbor	1
3	Hairspring Collet	1
4	Hairspring	1
5	Hand - Small	1
6	Hands - Small - Boss	1

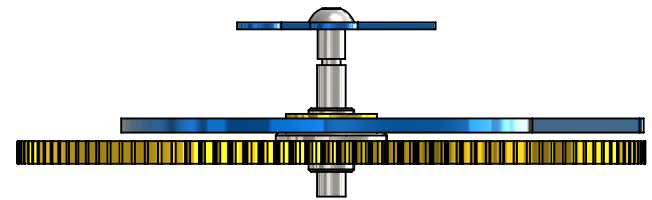
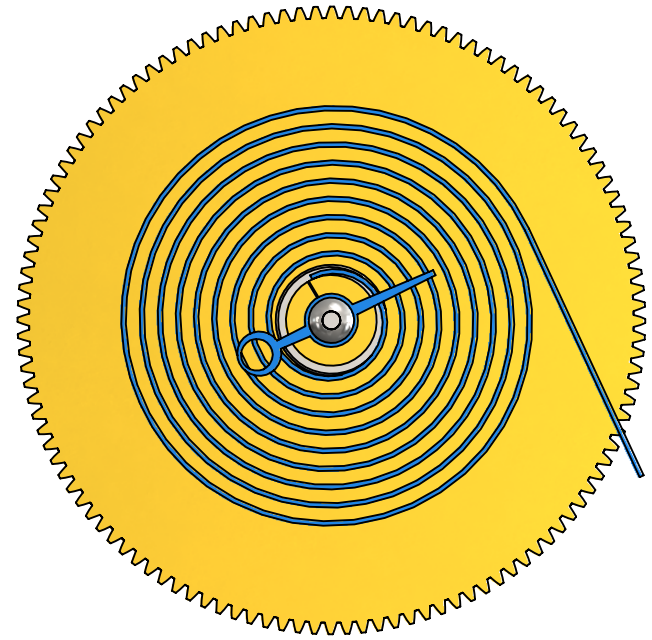
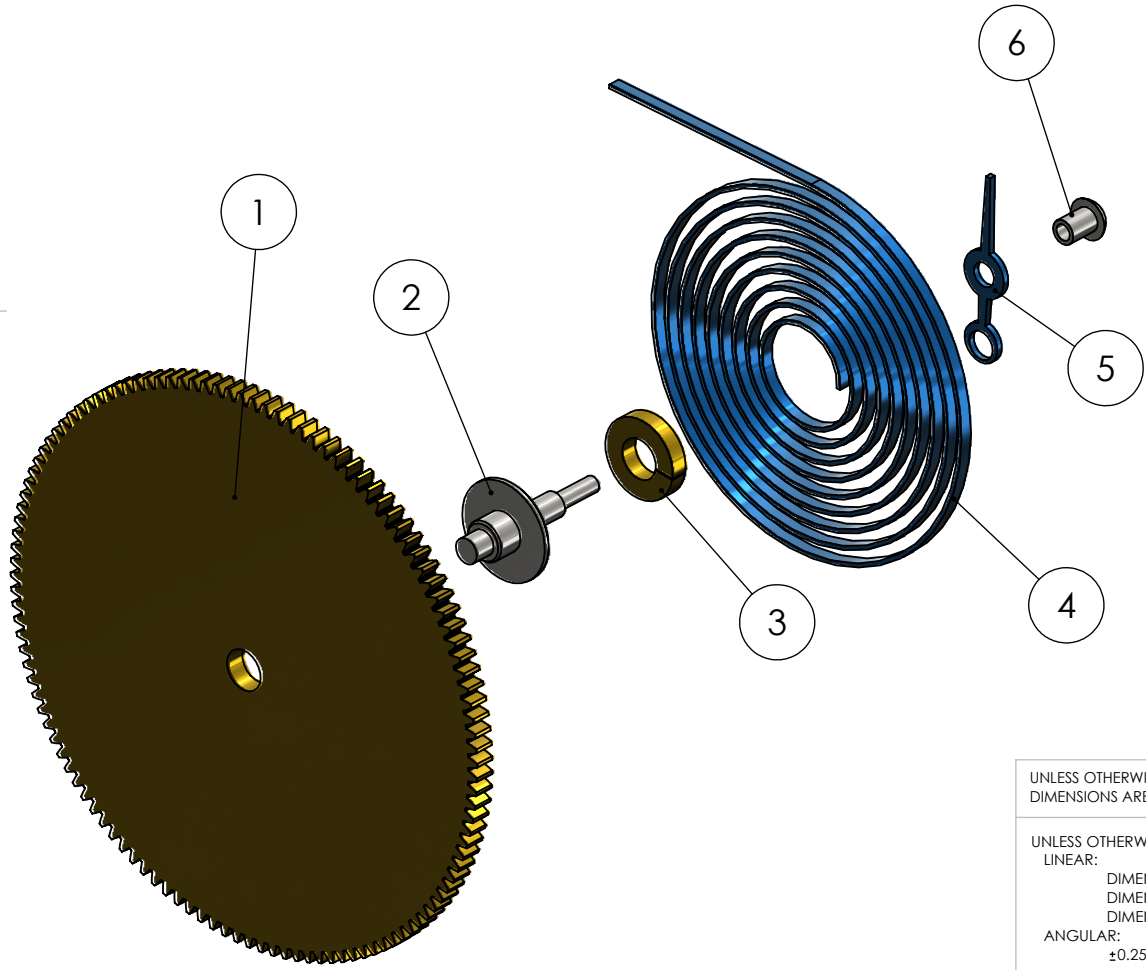

UNLESS OTHERWISE SPECIFIED:
DIMENSIONS ARE IN MILLIMETERS

UNLESS OTHERWISE SPECIFIED, TOLERANCES:
LINEAR:
DIMENSIONS ≤ 2 MM ± 0.01
DIMENSIONS > 2 MM & ≤ 50 MM ± 0.05
DIMENSIONS > 50 ± 0.15
ANGULAR:
 $\pm 0.25^\circ$

MATERIAL: BRASS, BLUED PIVOT STEEL

TITLE:
BACKLASH WHEEL ASSEMBLY

CLICKSPRINGPROJECTS.COM

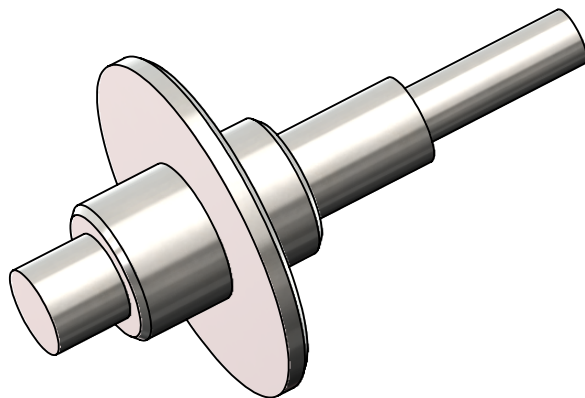
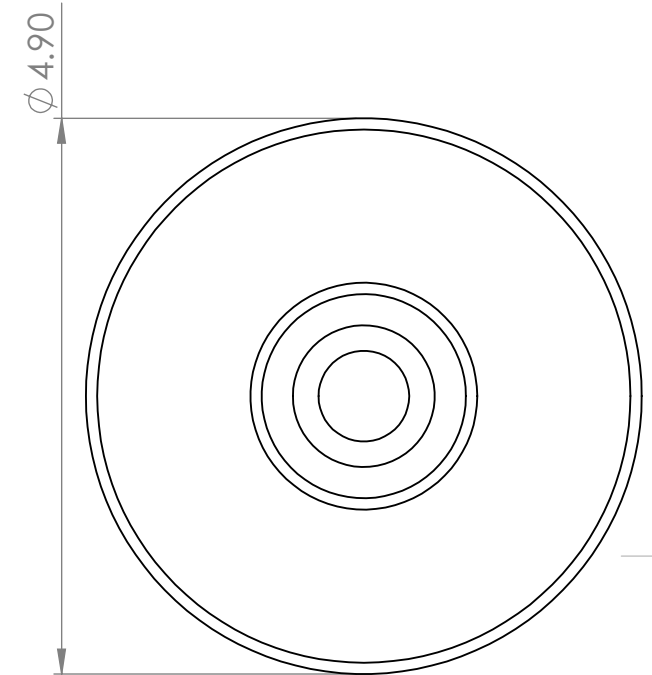
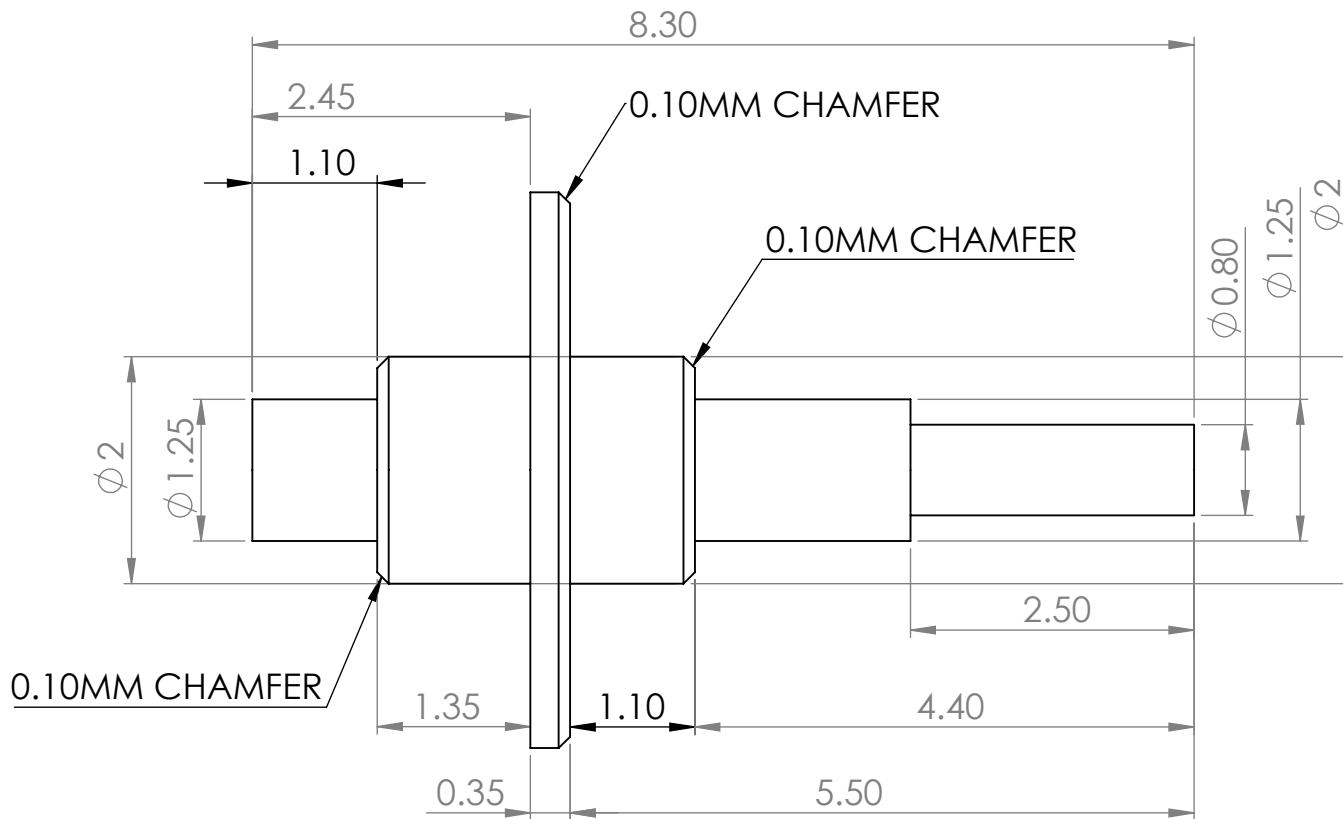

UNLESS OTHERWISE SPECIFIED:
DIMENSIONS ARE IN MILLIMETERS

UNLESS OTHERWISE SPECIFIED, TOLERANCES:
LINEAR:
DIMENSIONS ≤ 2 MM ± 0.01
DIMENSIONS > 2 MM & ≤ 50 MM ± 0.05
DIMENSIONS > 50 ± 0.15
ANGULAR:
 $\pm 0.25^\circ$

MATERIAL: BLUED PIVOT STEEL

TITLE:

BACKLASH WHEEL
ARBOR



CLICKSPRINGPROJECTS.COM

A4

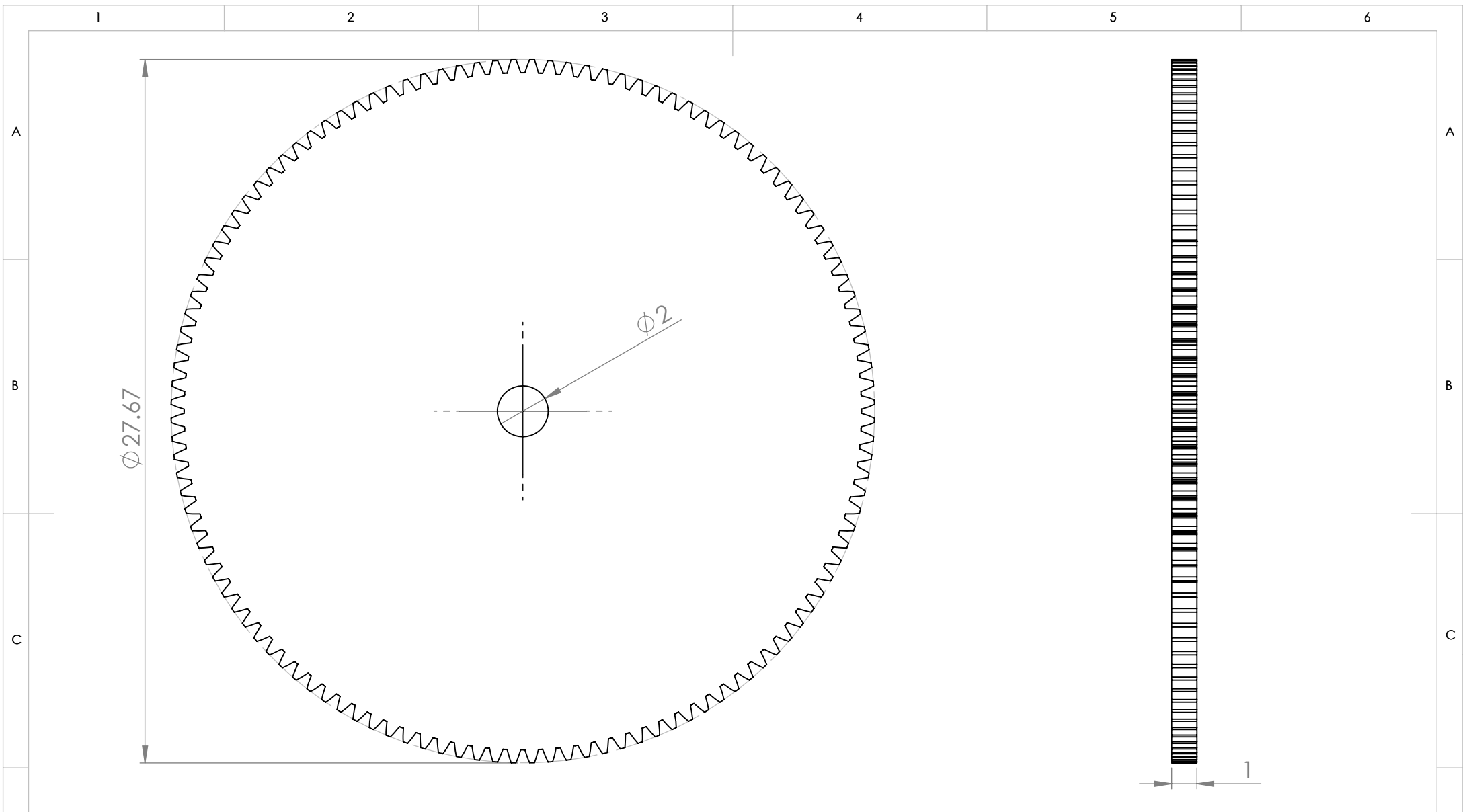

NOTES UNLESS OTHERWISE SPECIFIED:

- TEETH NUMBER = 120
- DIAMETRAL PITCH 112 / MODULE 0.2268

UNLESS OTHERWISE SPECIFIED:
DIMENSIONS ARE IN MILLIMETERS

UNLESS OTHERWISE SPECIFIED, TOLERANCES:
LINEAR:
DIMENSIONS <= 2 MM ± 0.01
DIMENSIONS > 2 MM & <= 50 MM ± 0.05
DIMENSIONS >50 ± 0.15
ANGULAR:
±0.25°

MATERIAL: BRASS

TITLE:
120T BACKLASH WHEEL



CLICKSPRINGPROJECTS.COM

A4

ITEM NO.	PART NUMBER	QTY.
1	12 T Center Pinion	1
2	Center Arbor	1
3	Hands - Main Long	1
4	Hands - Main Long - Boss	1

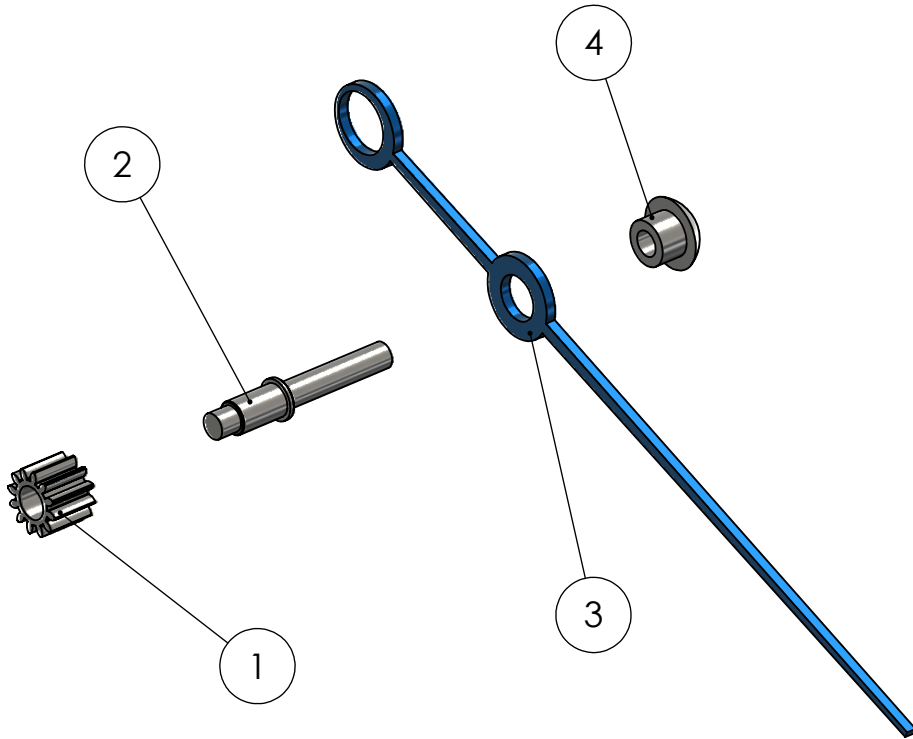
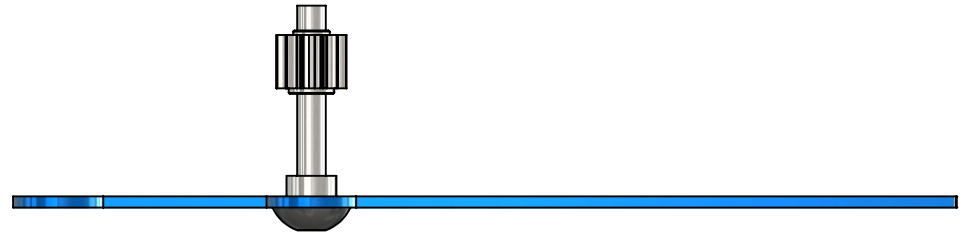
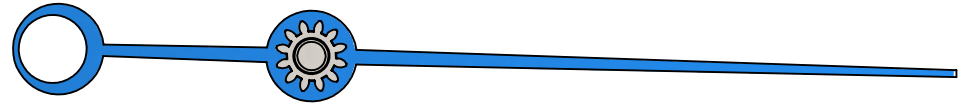

UNLESS OTHERWISE SPECIFIED:
DIMENSIONS ARE IN MILLIMETERS

UNLESS OTHERWISE SPECIFIED, TOLERANCES:
LINEAR:
DIMENSIONS <= 2 MM ± 0.01
DIMENSIONS > 2 MM & <= 50 MM ± 0.05
DIMENSIONS >50 ± 0.15

ANGULAR:
±0.25°

MATERIAL:

TITLE:
**CENTER PINION
ASSEMBLY**

 CLICKSPRINGPROJECTS.COM

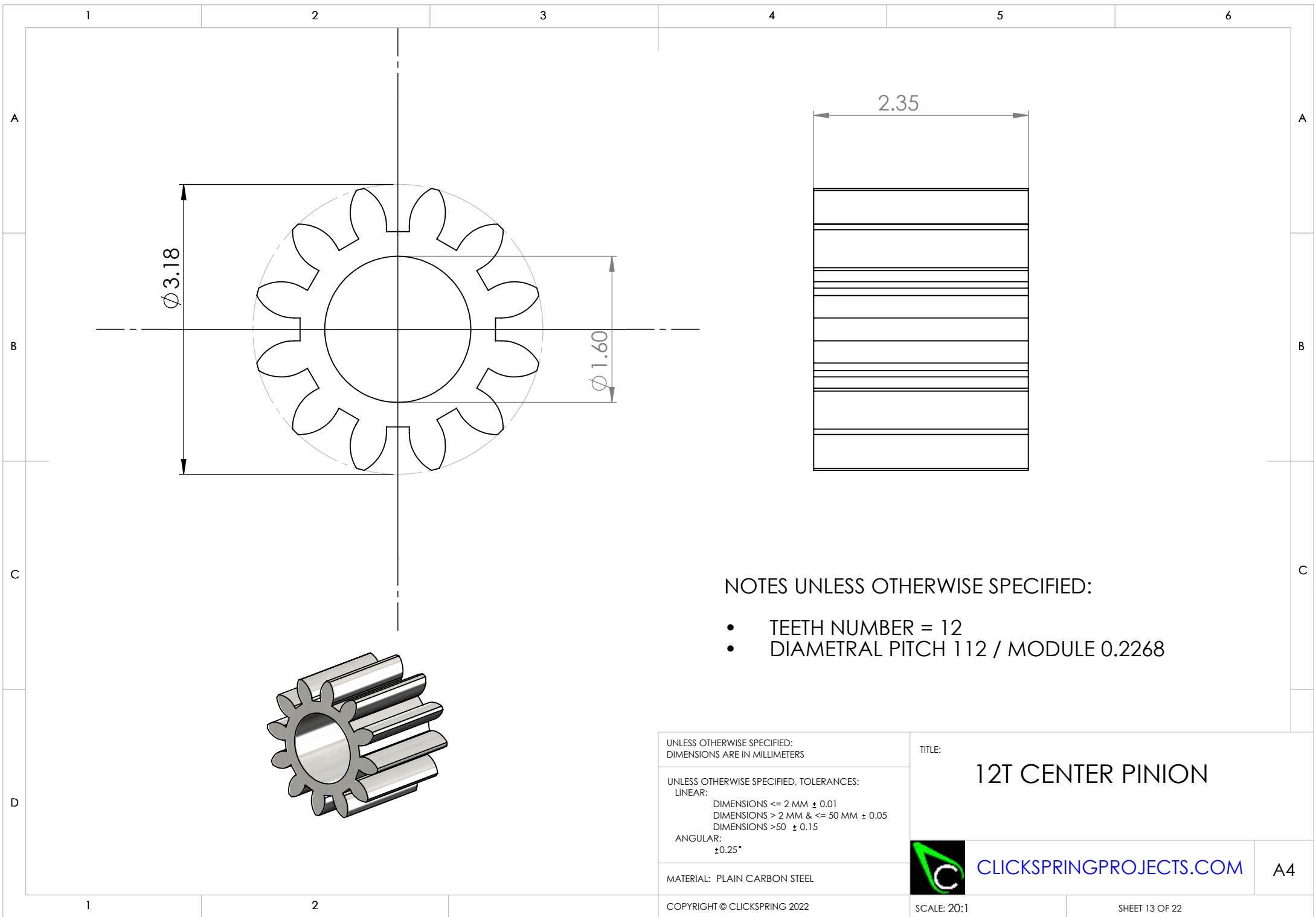

NOTES UNLESS OTHERWISE SPECIFIED:

- TEETH NUMBER = 12
- DIAMETRAL PITCH 112 / MODULE 0.2268

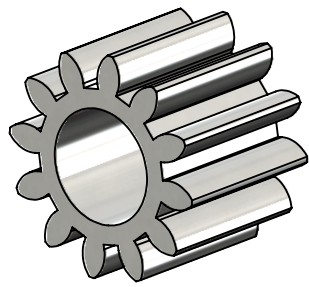

UNLESS OTHERWISE SPECIFIED:
DIMENSIONS ARE IN MILLIMETERS

UNLESS OTHERWISE SPECIFIED, TOLERANCES:
LINEAR:
DIMENSIONS <= 2 MM ± 0.01
DIMENSIONS > 2 MM & <= 50 MM ± 0.05
DIMENSIONS >50 ± 0.15

ANGULAR:
±0.25°

MATERIAL: PLAIN CARBON STEEL

TITLE:
12T CENTER PINION

 CLICKSPRINGPROJECTS.COM A4

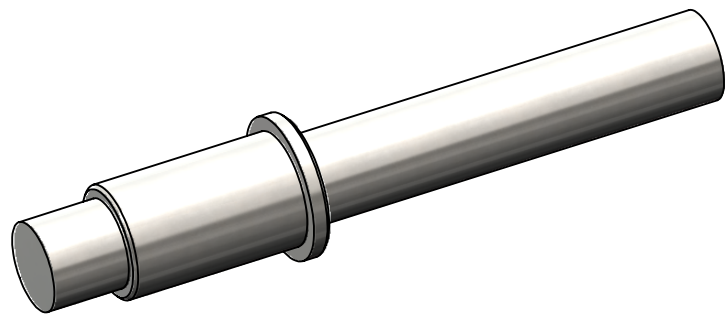
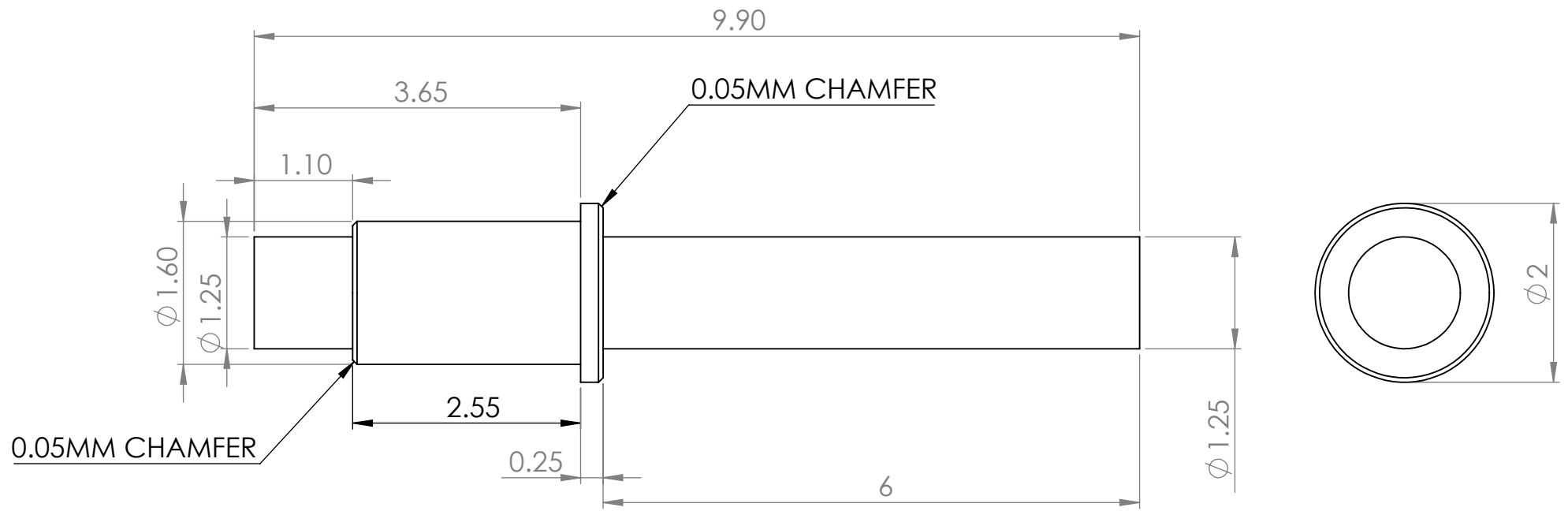

UNLESS OTHERWISE SPECIFIED:
DIMENSIONS ARE IN MILLIMETERS

UNLESS OTHERWISE SPECIFIED, TOLERANCES:
LINEAR:
DIMENSIONS ≤ 2 MM ± 0.01
DIMENSIONS > 2 MM & ≤ 50 MM ± 0.05
DIMENSIONS > 50 ± 0.15
ANGULAR:
 $\pm 0.25^\circ$

MATERIAL: PLAIN CARBON STEEL

TITLE:

CENTER ARBOR



CLICKSPRINGPROJECTS.COM

A4

ITEM NO.	PART NUMBER	QTY.
1	Indicator Shaft	1
2	Spring Retaining Cup	1
3	Spring Retaining Pin	1
4	Return Spring	1
5	Guide Pin	1
6	Indicator Shaft Tip	2

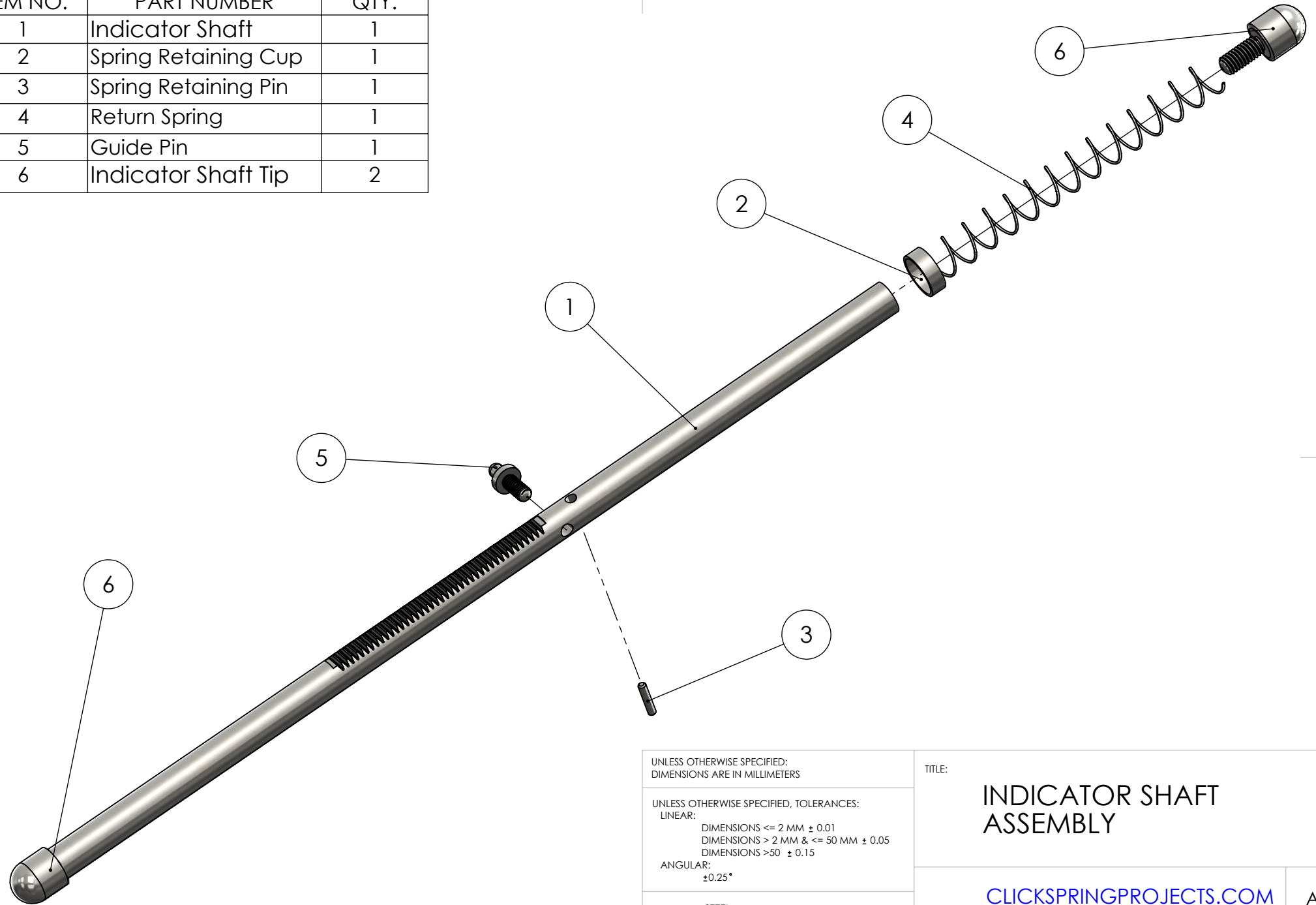

UNLESS OTHERWISE SPECIFIED:
DIMENSIONS ARE IN MILLIMETERS

UNLESS OTHERWISE SPECIFIED, TOLERANCES:
LINEAR:
DIMENSIONS ≤ 2 MM ± 0.01
DIMENSIONS > 2 MM & ≤ 50 MM ± 0.05
DIMENSIONS > 50 ± 0.15

ANGULAR:
 $\pm 0.25^\circ$

MATERIAL: STEEL

TITLE:
**INDICATOR SHAFT
ASSEMBLY**

CLICKSPRINGPROJECTS.COM

A4

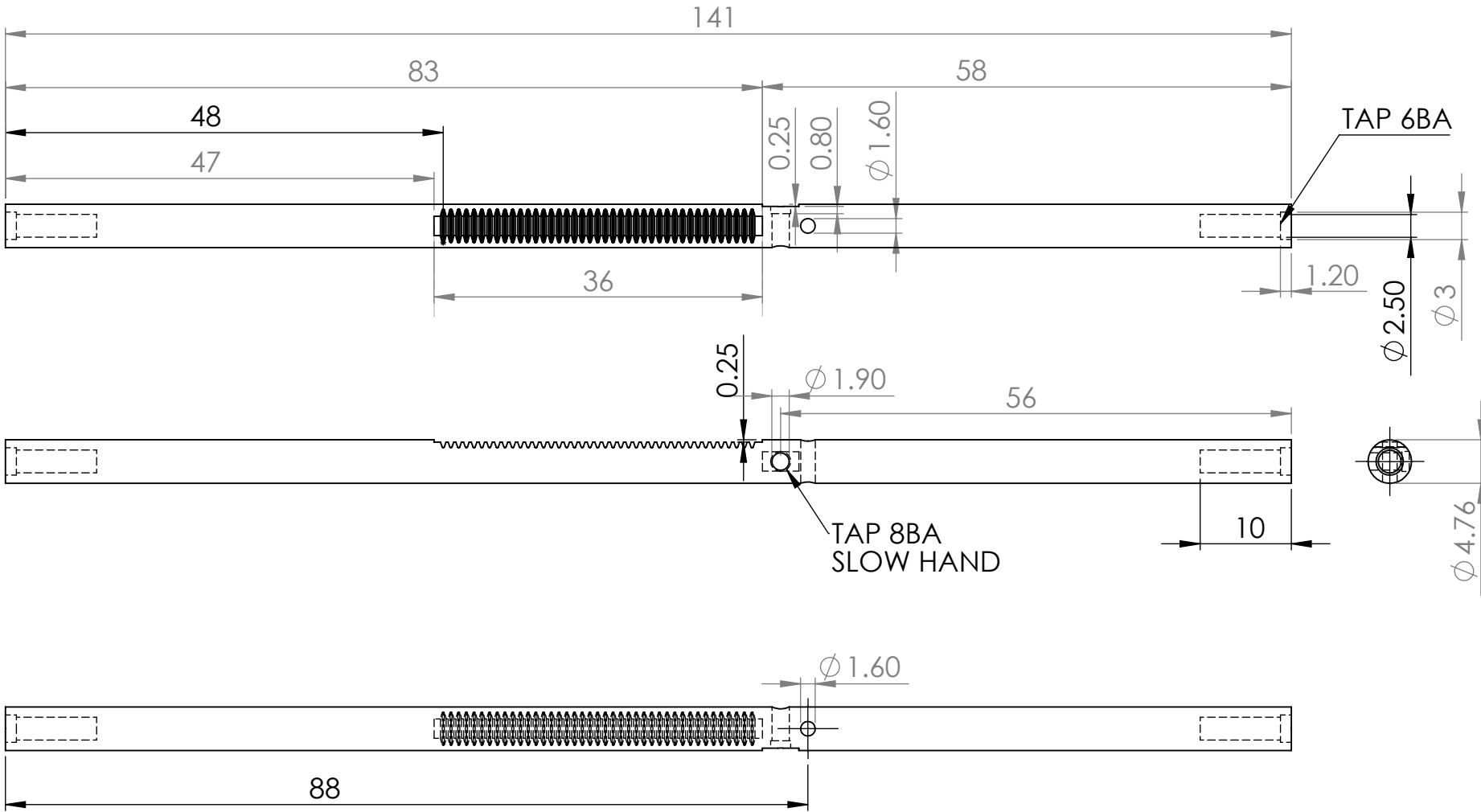

NOTES UNLESS OTHERWISE SPECIFIED:

- TEETH NUMBER = 41 (30 / INCH)
- DIAMETRAL PITCH 94.25 / MODULE 0.2695
- LINEAR PITCH 0.033

UNLESS OTHERWISE SPECIFIED:
DIMENSIONS ARE IN MILLIMETERS

UNLESS OTHERWISE SPECIFIED, TOLERANCES:
LINEAR:
DIMENSIONS ≤ 2 MM ± 0.01
DIMENSIONS > 2 MM & ≤ 50 MM ± 0.05
DIMENSIONS > 50 ± 0.15
ANGULAR:
 $\pm 0.25^\circ$

MATERIAL: O1 TOOL STEEL

TITLE:

INDICATOR SHAFT



CLICKSPRINGPROJECTS.COM

A4

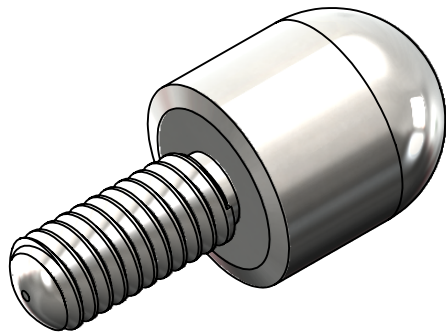
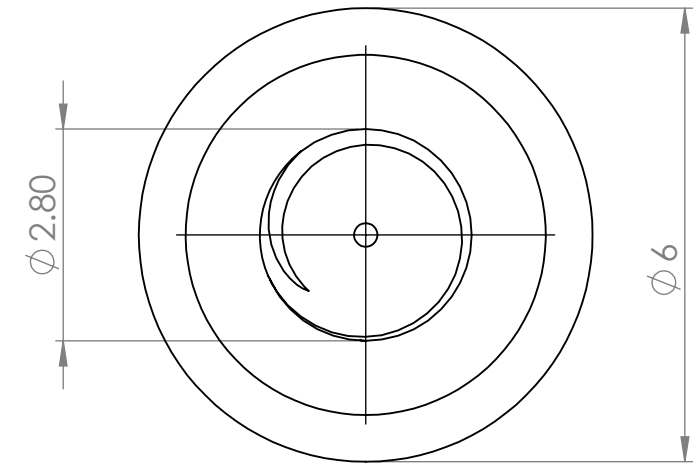
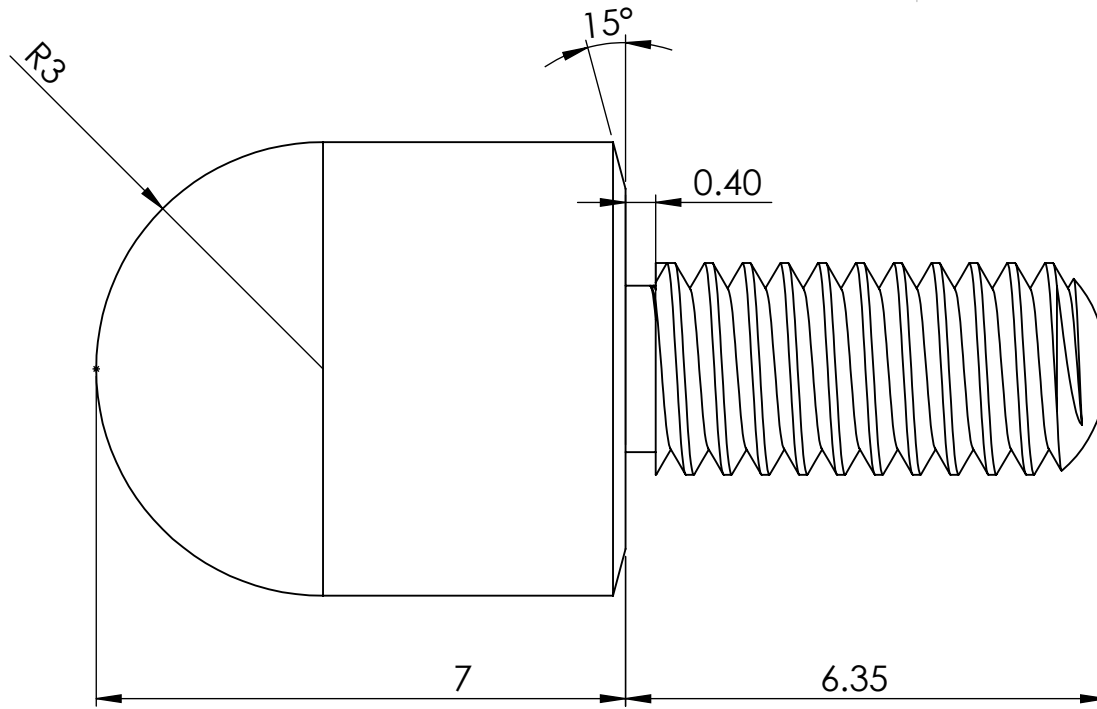

NOTES UNLESS OTHERWISE SPECIFIED:

- THREAD 6BA

UNLESS OTHERWISE SPECIFIED:
DIMENSIONS ARE IN MILLIMETERS

UNLESS OTHERWISE SPECIFIED, TOLERANCES:
LINEAR:
DIMENSIONS ≤ 2 MM ± 0.01
DIMENSIONS > 2 MM & ≤ 50 MM ± 0.05
DIMENSIONS > 50 ± 0.15
ANGULAR:
 $\pm 0.25^\circ$

MATERIAL: MEDIUM CARBON STEEL (EG EN8)

TITLE:

INDICATOR SHAFT TIP



CLICKSPRINGPROJECTS.COM

A4

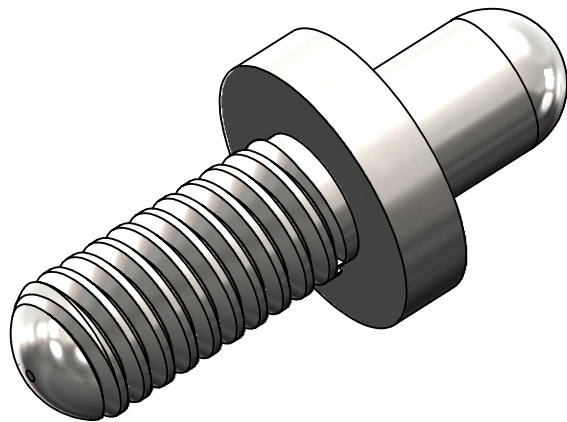
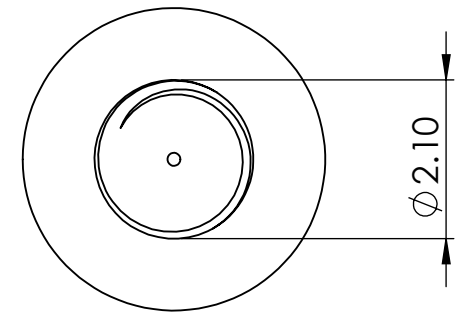
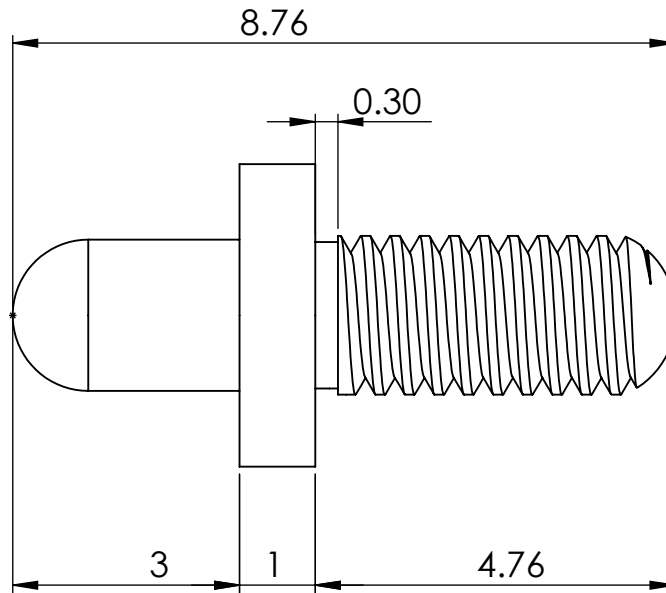
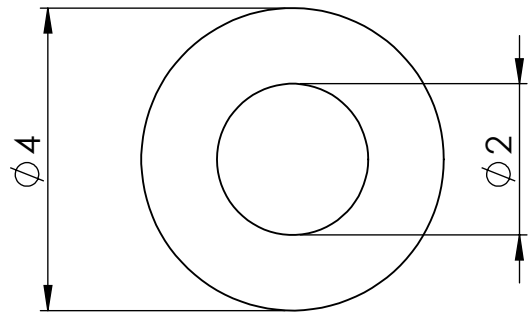

NOTES UNLESS OTHERWISE SPECIFIED:

- THREAD 8BA

UNLESS OTHERWISE SPECIFIED:
DIMENSIONS ARE IN MILLIMETERS

UNLESS OTHERWISE SPECIFIED, TOLERANCES:
LINEAR:
DIMENSIONS ≤ 2 MM ± 0.01
DIMENSIONS > 2 MM & ≤ 50 MM ± 0.05
DIMENSIONS > 50 ± 0.15
ANGULAR:
 $\pm 0.25^\circ$

MATERIAL: PLAIN CARBON STEEL

TITLE:

GUIDE PIN



CLICKSPRINGPROJECTS.COM

A4

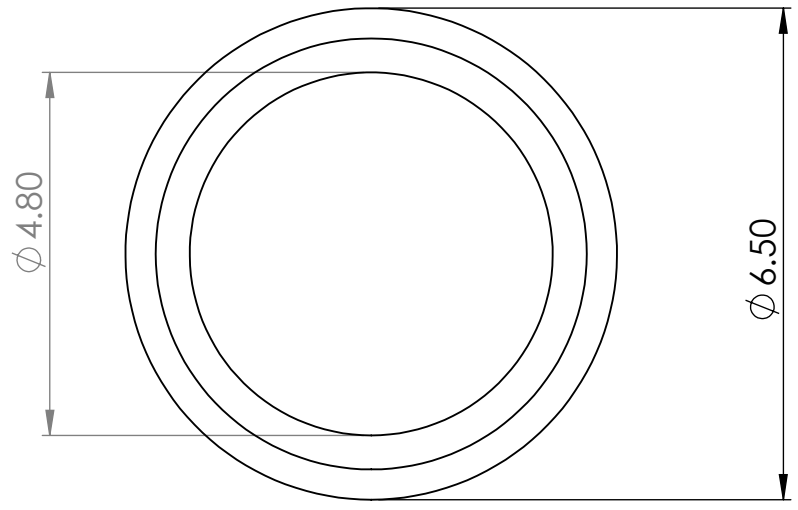
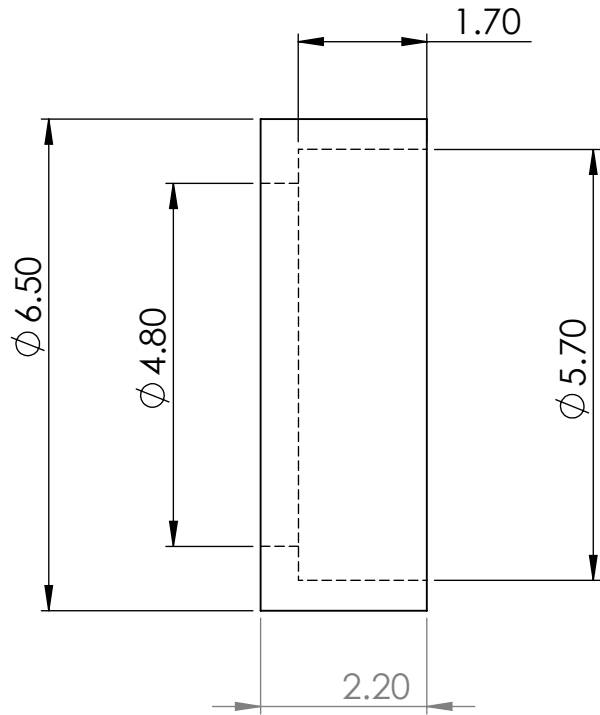

UNLESS OTHERWISE SPECIFIED:
DIMENSIONS ARE IN MILLIMETERS

UNLESS OTHERWISE SPECIFIED, TOLERANCES:
LINEAR:
DIMENSIONS ≤ 2 MM ± 0.01
DIMENSIONS > 2 MM & ≤ 50 MM ± 0.05
DIMENSIONS > 50 ± 0.15
ANGULAR:
 $\pm 0.25^\circ$

MATERIAL: PLAIN CARBON STEEL

TITLE:
SPRING RETAINING CUP



CLICKSPRINGPROJECTS.COM

A4

ITEM NO.	PART NUMBER	QTY.
1	Ind. Shaft Fixture Body	1
2	Ind. Shaft Fixture Pin	2
3	Grub Screw	2
4	Indicator Shaft	1

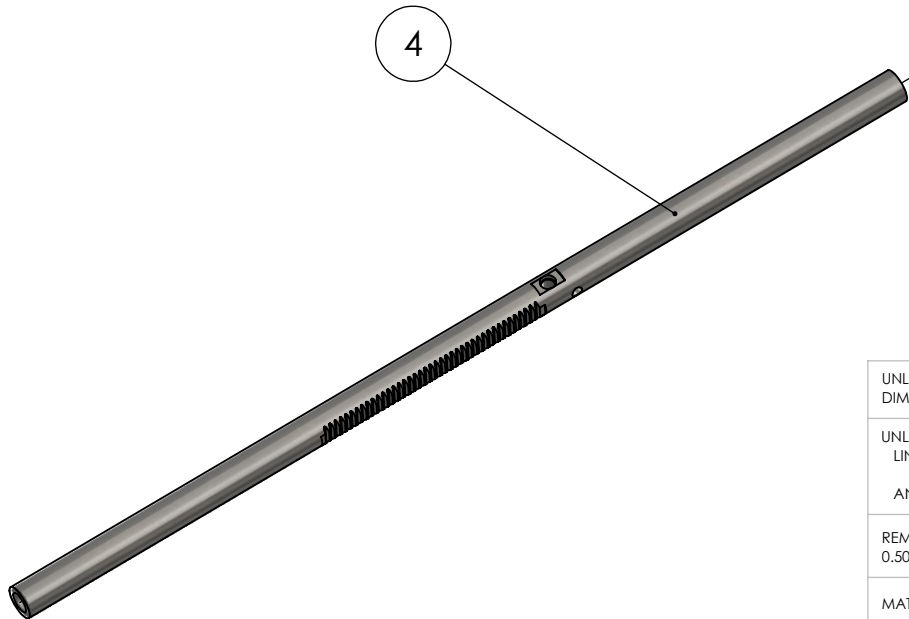
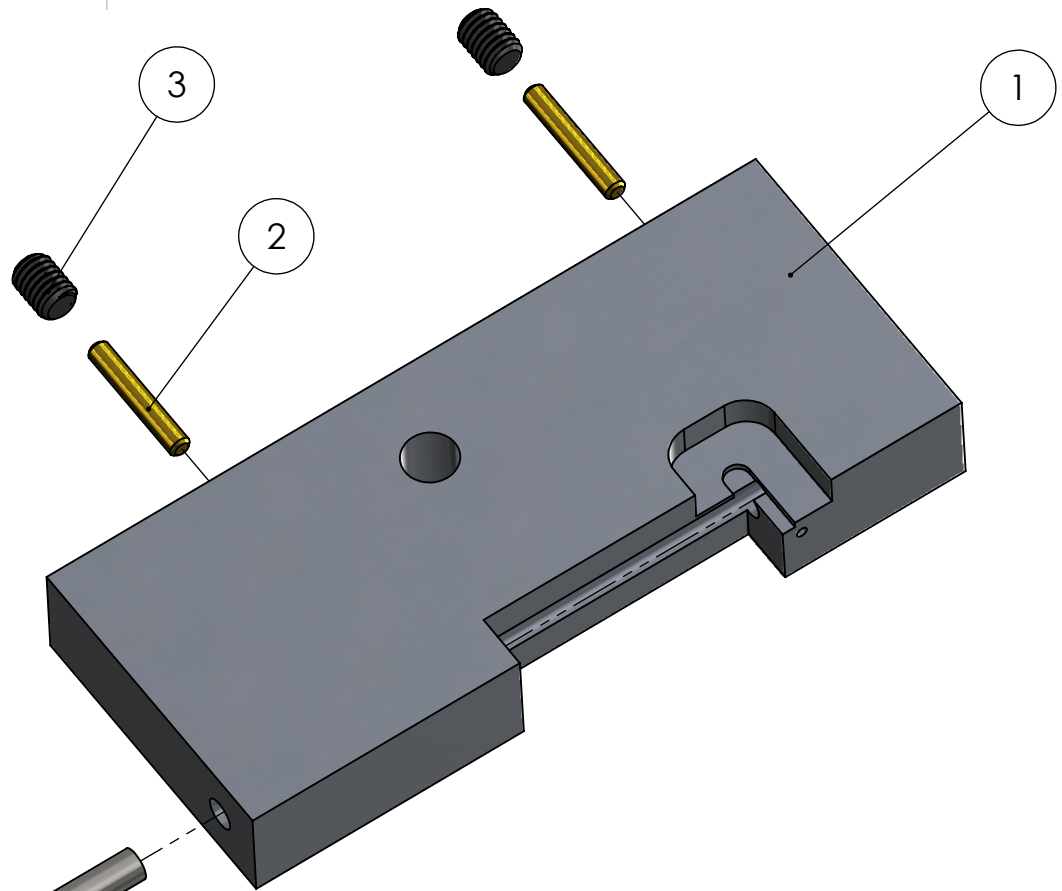

UNLESS OTHERWISE SPECIFIED:
DIMENSIONS ARE IN MILLIMETERS

UNLESS OTHERWISE SPECIFIED, TOLERANCES:
LINEAR: DIMENSIONS UNDER 15 MM ± 0.3
DIMENSIONS 15 MM AND OVER ± 1
ANGULAR: $\pm 0.5^\circ$

REMOVE ALL BURRS AND SHARP EDGES
0.50 RADIUS OR CHAMFER MAX

MATERIAL: 1060 ALLOY, BRASS, STEEL

TITLE:
**INDICATOR SHAFT
FIXTURE ASSEMBLY**

CLICKSPRINGPROJECTS.COM

A4

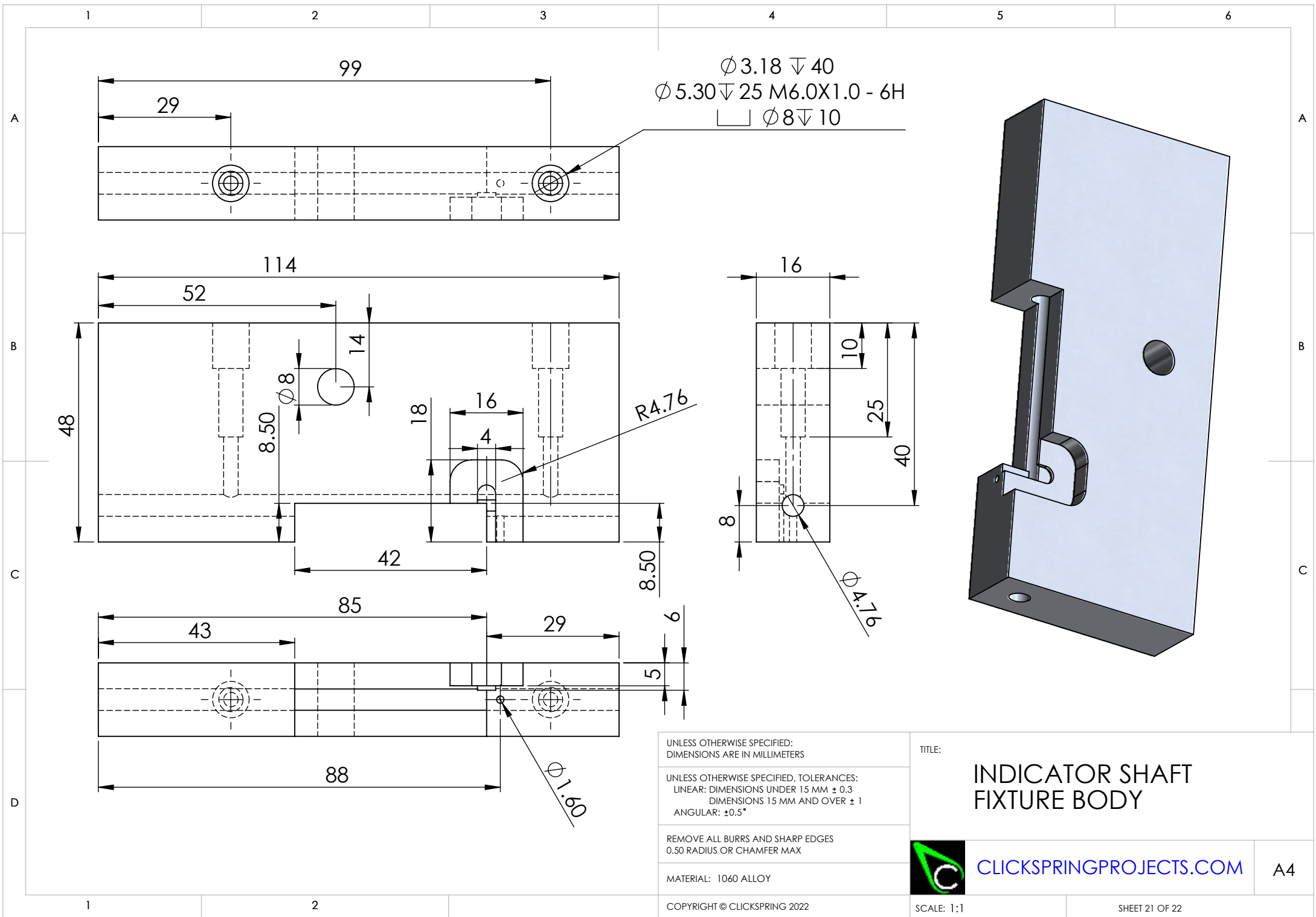

UNLESS OTHERWISE SPECIFIED:
DIMENSIONS ARE IN MILLIMETERS

UNLESS OTHERWISE SPECIFIED, TOLERANCES:
LINEAR: DIMENSIONS UNDER 15 MM ± 0.3
DIMENSIONS 15 MM AND OVER ± 1
ANGULAR: $\pm 0.5^\circ$

REMOVE ALL BURRS AND SHARP EDGES
0.50 RADIUS OR CHAMFER MAX

MATERIAL: 1060 ALLOY

COPYRIGHT © CLICKSPRING 2022

TITLE:

INDICATOR SHAFT FIXTURE BODY



CLICKSPRINGPROJECTS.COM

A4

SCALE: 1:1

SHEET 21 OF 22

1 2 3 4 5 6

A

A

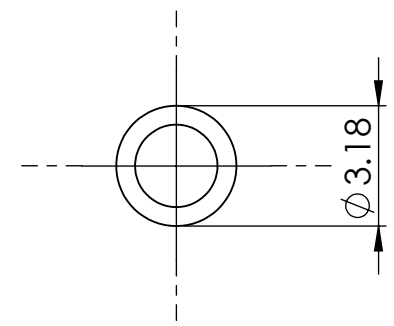
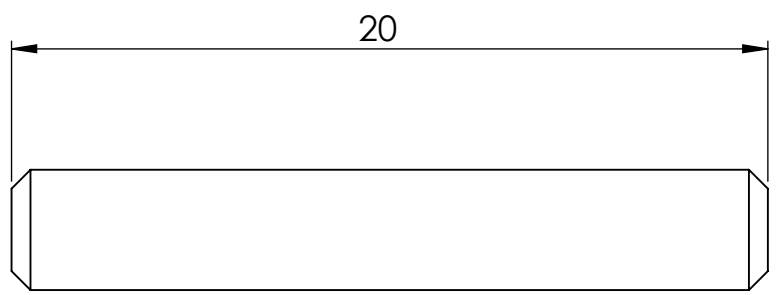

B

B

C

C

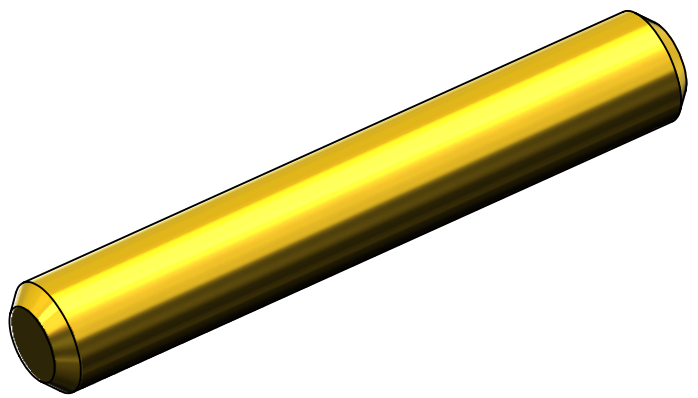

D

D

UNLESS OTHERWISE SPECIFIED:
DIMENSIONS ARE IN MILLIMETERS

UNLESS OTHERWISE SPECIFIED, TOLERANCES:
LINEAR: DIMENSIONS UNDER 15 MM ± 0.3
DIMENSIONS 15 MM AND OVER ± 1
ANGULAR: $\pm 0.5^\circ$

REMOVE ALL BURRS AND SHARP EDGES
0.50 RADIUS OR CHAMFER MAX

MATERIAL: BRASS

TITLE:

INDICATOR SHAFT CUTTING FIXTURE PIN



CLICKSPRINGPROJECTS.COM

A4